



**Installation, Service & Maintenance Manual**  
for AC generators with the following prefixes:  
**HCI; HCM; HCK 4,5,6,7.**



# SAFETY PRECAUTIONS

Before operating the generating set, read the generating set operation manual and this generator manual and become familiar with it and the equipment.

## **SAFE AND EFFICIENT OPERATION CAN ONLY BE ACHIEVED IF THE EQUIPMENT IS CORRECTLY OPERATED AND MAINTAINED.**

Many accidents occur because of failure to follow fundamental rules and precautions.

## **ELECTRICAL SHOCK CAN CAUSE SEVERE PERSONAL INJURY OR DEATH.**

Observe all **WARNING/CAUTION** notices.

- Ensure installation meets all applicable safety and local electrical codes. Have all installations performed by a qualified electrician.
- Do not operate the generator with protective covers, access covers or terminal box covers removed.
- Disable engine starting circuits before carrying out maintenance.
- Disable closing circuits and/or place warning notices on any circuit breakers normally used for connection to the mains or other generators, to avoid accidental closure.

Observe all **IMPORTANT**, **CAUTION**, **WARNING**, and **DANGER** notices, defined as:

**Important ! Important refers to hazard or unsafe method or practice which can result in product damage or related equipment damage.**

**Caution ! Caution refers to hazard or unsafe method or practice which can result in product damage or personal injury.**

  
**Warning ! Warning refers to a hazard or unsafe method or practice which CAN result in severe personal injury or possible death.**

  
**Danger ! Danger refers to immediate hazards which WILL result in severe personal injury or death.**

Due to our policy of continuous improvement, details in this manual which were correct at time of printing, may now be due for amendment. Information included must therefore not be regarded as binding.

### **Front Cover Photograph**

This photograph is representative only. Several variations are available within the range of generators covered by this manual.

# FOREWORD

The function of this book is to provide the user of the Stamford generator with an understanding of the principles of operation, the criteria for which the generator has been designed, and the installation and maintenance procedures. Specific areas where the lack of care or use of incorrect procedures could lead to equipment damage and/or personal injury are highlighted, with **WARNING** and/or **CAUTION** notes, and it is important that the contents of this book are read and understood before proceeding to fit or use the generator.

The Service, Sales and technical staff of Newage International are always ready to assist and reference to the company for advice is welcomed.



**Incorrect installation, operation, servicing or replacement of parts can result in severe personal injury or death, and/or equipment damage. Service personnel must be qualified to perform electrical and mechanical service.**

**Warning !**

## EC DECLARATION OF INCORPORATION

All Stamford generators are supplied with a declaration of incorporation for the relevant EC legislation, typically in the form of a label as below.

 <b>EC DECLARATION OF INCORPORATION</b>	
<small>IN ACCORDANCE WITH THE SUPPLY OF MACHINERY (SAFETY) REGULATIONS 1992 AND THE SUPPLY OF MACHINERY (SAFETY) (AMENDMENT) REGULATIONS 1994 IMPLEMENTING THE EC MACHINERY DIRECTIVE 89/392/EEC AS AMENDED BY 91/368/EEC.</small>	
<small>THIS STAMFORD A.C. GENERATOR WAS MANUFACTURED BY OR ON BEHALF OF <b>NEWAGE INTERNATIONAL LTD</b> BARNACK ROAD STAMFORD LINCOLNSHIRE ENGLAND.</small>	
<small>THIS COMPONENT MACHINERY MUST NOT BE PUT INTO SERVICE UNTIL THE MACHINERY INTO WHICH IT IS TO BE INCORPORATED HAS BEEN DECLARED IN CONFORMITY WITH THE PROVISIONS OF THE SUPPLY OF MACHINERY (SAFETY) REGULATIONS 1995/MACHINERY DIRECTIVE.</small>	
<small>FOR AND ON BEHALF OF NEWAGE INTERNATIONAL LIMITED</small>	
<small>NAME:</small>	<small>LAWRENCE HAYDOCK</small>
<small>POSITION:</small>	<small>TECHNICAL DIRECTOR</small>
<small>SIGNATURE:</small>	
<small>THIS COMPONENT MACHINERY CARRIES THE CE MARK FOR COMPLIANCE WITH THE STATUTORY REQUIREMENTS FOR THE IMPLEMENTATION OF THE FOLLOWING DIRECTIVES</small>	
<small>The EMC Directive 89/336/EEC</small>	
<small>WARNING:</small>	<small>This Component Machinery shall not be used in the Residential, Commercial and Light Industrial environment unless it also conforms to the relevant standard (EN 50081 - 1) REFER TO FACTORY FOR DETAILS</small>
<small>   The Low Voltage Directive 73/23/EEC as amended by 93/68/EEC</small>	



## ELECTROMAGNETIC COMPATIBILITY

### Additional Information

#### European Union

#### Council Directive 89/336/EEC

For installations within the European Union, electrical products must meet the requirements of the above directive, and Newage ac generators are supplied on the basis that:

- They are to be used for power-generation or related function.
- They are to be applied in one of the following environments:

Portable (open construction - temporary site supply)  
Portable (enclosed - temporary site supply)  
Containerised (temporary or permanent site supply)  
Ship-borne below decks (marine auxiliary power)  
Commercial vehicle (road transport / refrigeration etc)  
Rail transport (auxiliary power)  
Industrial vehicle (earthmoving, cranes etc)  
Fixed installation (industrial - factory / process plant)  
Fixed installation (residential, commercial and light industrial - home / office / health)  
Energy management (Combined heat and power and/or peak lopping)  
Alternative energy schemes.

- The standard generators are designed to meet the 'industrial' emissions and immunity standards. Where the generator is required to meet the residential, commercial and light industrial emissions and immunity standards reference should be made to Newage document reference N4/X/011, as additional equipment may be required.
- The installation earthing scheme involves connection of the generator frame to the site protective earth conductor using a minimum practical lead length.
- Maintenance and servicing with anything other than factory supplied or authorised parts will invalidate any Newage liability for EMC compliance.
- Installation, maintenance and servicing is carried out by adequately trained personnel fully aware of the requirements of the relevant EC directives

# CONTENTS

<b>SAFETY PRECAUTIONS</b>			<b>IFC</b>
<b>FOREWORD</b>			<b>1</b>
<b>CONTENTS</b>			<b>2&amp;3</b>
<b>SECTION 1</b>		<b>INTRODUCTION</b>	<b>4</b>
	1.1	INTRODUCTION	4
	1.2	DESIGNATION	4
	1.3	SERIAL NUMBER LOCATION	4
	1.4	RATING PLATE AND CE MARK	4
<b>SECTION 2</b>		<b>PRINCIPLE OF OPERATION</b>	<b>5</b>
	2.1	SELF-EXCITED AVR CONTROLLED GENERATORS	5
	2.2	PERMANENT MAGNET GENERATOR (PMG) EXCITED - AVR CONTROLLED GENERATORS	5
	2.3	AVR ACCESSORIES	5
<b>SECTION 3</b>		<b>APPLICATION OF THE GENERATOR</b>	<b>6</b>
<b>SECTION 4</b>		<b>INSTALLATION - PART 1</b>	<b>8</b>
	3.1	VIBRATION	7
	4.1	LIFTING	8
	4.2	ENGINE TO GENERATOR COUPLING ASSEMBLY	8
	4.2.1	TWO BEARING GENERATORS	8
	4.2.2	SINGLE BEARING GENERATORS TYPES HC & HCK	8
	4.3	EARTHING	9
	4.4	PRE-RUNNING CHECKS	9
	4.4.1	INSULATION CHECK	9
	4.4.2	DIRECTION OF ROTATION	9
	4.4.2.1	FAN TYPES	9
	4.4.2.2	DIRECTION OF ROTATION	9
	4.4.3	VOLTAGE AND FREQUENCY	9
	4.4.4	AVR SETTINGS	9
	4.4.4.1	TYPE SX440 AVR	10
	4.4.4.2	TYPE SX421 AVR	10
	4.4.4.3	TYPE MX341 AVR	10
	4.4.4.4	TYPE MX321 AVR	11
	4.5	GENERATOR SET TESTING	11
	4.5.1	TEST METERING/CABLING	11
	4.6	INITIAL START-UP	11
	4.7	LOAD TESTING	12
	4.7.1	AVR ADJUSTMENTS	12
	4.7.1.1	UFRO (Under Frequency Roll Off) (AVR Types SX440, SX421, MX341 and MX321)	13
	4.7.1.2	EXC TRIP (Excitation Trip)	13
	4.7.1.3	OVER/V (Over Voltage)	13
	4.7.1.4	TRANSIENT LOAD SWITCHING ADJUSTMENTS	13
	4.7.1.5	RAMP	14
	4.8	ACCESSORIES	14
<b>SECTION 5</b>		<b>INSTALLATION - PART 2</b>	<b>14</b>
	5.1	GENERAL	14
	5.2	GLANDING	14
	5.3	MAXIMUM TORQUE SETTINGS FOR CUSTOMER TERMINAL CONNECTIONS	14
	5.4	EARTHING	14
	5.5	PROTECTION	14
	5.6	COMMISSIONING	14

# CONTENTS

<b>SECTION 6</b>	<b>ACCESSORIES</b>	<b>15</b>
6.1	REMOTE VOLTAGE ADJUST (ALL AVR TYPES)	15
6.2	PARALLEL OPERATION	15
6.2.1	DROOP	15
6.2.1.1	SETTING PROCEDURE	16
6.2.2	ASTATIC CONTROL	16
6.3	MANUAL VOLTAGE REGULATOR (MVR) - MX341 and MX321 AVR	16
6.4.	OVERVOLTAGE DE-EXCITATION BREAKER SX421 and MX321 AVR	16
6.4.1	RESETTING THE EXCITATION BREAKER	17
6.5	CURRENT LIMIT - MX321 AVR	17
6.5.1	SETTING PROCEDURE	17
6.6	POWER FACTOR CONTROLLER (PFC3)	17
<b>SECTION 7</b>	<b>SERVICE AND MAINTENANCE</b>	<b>18</b>
7.1	WINDING CONDITION	18
7.1.1	WINDING CONDITION ASSESSMENT	18
7.1.2	METHODS OF DRYING OUT GENERATORS	18
7.2	BEARINGS	19
7.3	AIR FILTERS	21
7.3.1	CLEANING PROCEDURE	21
7.3.2	RECHARGING (CHARGING)	21
7.4	FAULT FINDING	21
7.4.1	SX440 AVR - FAULT FINDING	21
7.4.2	SX421 AVR - FAULT FINDING	21
7.4.3	MX341 AVR - FAULT FINDING	22
7.4.4	MX321 AVR - FAULT FINDING	22
7.4.5	RESIDUAL VOLTAGE CHECK	22
7.4.6	REFLASHING TO RESTORE RESIDUAL	22
7.5	SEPARATE EXCITATION TEST PROCEDURE	23
7.5.1	GENERATOR WINDINGS, ROTATING DIODES and PERMANENT MAGNET GENERATOR (PMG)	23
7.5.1.1	BALANCED MAIN TERMINAL VOLTAGES	23
7.5.1.2	UNBALANCED MAIN TERMINAL VOLTAGES	24
7.5.2	EXCITATION CONTROL TEST	25
7.5.2.1	AVR FUNCTION TEST	25
7.5.3	REMOVAL AND REPLACEMENT OF COMPONENT ASSEMBLIES	25
7.5.3.1	ANTI-CONDENSATION HEATERS	25
7.5.3.2	REMOVAL OF PERMANENT MAGNET GENERATOR (PMG)	25
7.5.3.3	REMOVAL OF BEARINGS	25
7.5.3.4	MAIN ROTOR ASSEMBLY	29
7.6	RETURNING TO SERVICE	30
7.7	MAINTENANCE OF REGREASABLE BEARINGS	30
<b>SECTION 8</b>	<b>SPARES AND AFTER SALES SERVICE</b>	<b>31</b>
8.1	RECOMMENDED SPARES	31
8.2	AFTER SALES SERVICE	31

# SECTION 1

## INTRODUCTION

### 1.1 INTRODUCTION

The HC range of generators is of brushless rotating field design, available up to 660V at 50 Hz or 60 Hz and built to meet BS5000 Part 3 and international standards.

1500 rpm (50Hz) or 1800 rpm (60Hz) 4 pole generators are available from 200kW to 2000kW in four frame sizes - HC4, HC5, HC6 and HC7.

1000 rpm (50Hz) or 1200 rpm (60Hz) 6 pole generators are available from 224kW to 1300kW in two frame sizes - HC6 and HC7.

Frame sizes HC4 and HC5 may be provided with a stator fed excitation system using SX440 or SX421 AVR, or with the permanent magnet generator (PMG) powered excitation system, using the MX341 or MX321 AVR.

Frames HC6 and HC7 are fitted with the PMG system using the MX321 AVR.

### 1.2 DESIGNATION

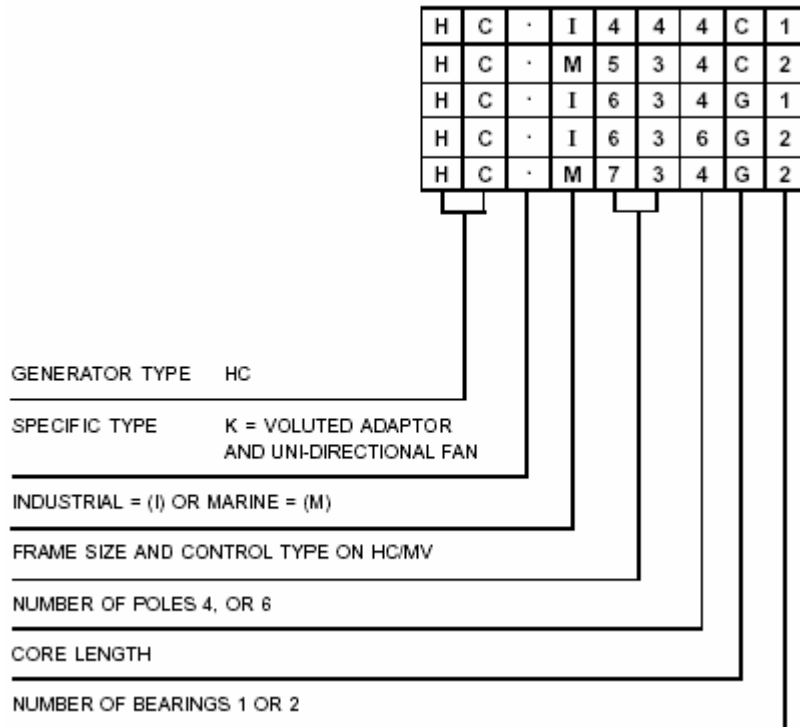

### 1.3 SERIAL NUMBER LOCATION

Each generator has its unique serial number stamped in to the upper section of the drive end frame end-ring.

Inside the terminal box two adhesive rectangular labels have been fixed, each carrying the generators unique identity number. One label has been fixed to the inside of the terminal box sheet metal work, and the second label fixed to the main frame of the generator.

### 1.4 RATING PLATE AND CE MARK

The generator has been supplied with a self adhesive rating plate label to enable fitting after final assembly and painting. It is intended that this label will be stuck to the outside of the non drive end of the terminal box.

A CE Mark label is also supplied loose for fitment after final assembly and painting. This should be attached to an external surface of the Generator at a suitable location where it will not be obscured by the customer's wiring or other fittings. Before fitting the CE Mark label the genset builder must address the requirements of the relevant EC legislation to ensure the compliance of the genset as a whole. CE compliance will also need to be addressed when installed on site.

The surface in the area where a label is to be stuck must be flat, clean, and any paint finish be fully dry before attempting to attach label. Recommended method for attaching label is peel and fold back sufficient of the backing paper to expose some 20 mm of label adhesive along the edge which is to be located against the sheet metal protrusions. Once this first section of label has been carefully located and stuck into position the backing paper can be progressively removed, as the label is pressed down into position. The adhesive will achieve a permanent bond in 24 hours.

# SECTION 2

## PRINCIPLE OF OPERATION

### 2.1 SELF-EXCITED AVR CONTROLLED GENERATORS

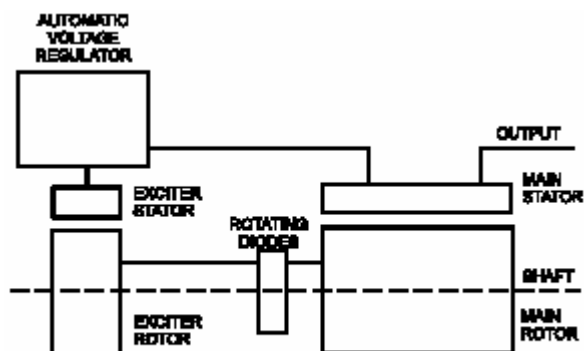

**Fig. 1**  
**Fig. 1**

The main stator provides power for excitation of the exciter field via the SX440 (or SX421) AVR which is the controlling device governing the level of excitation provided to the exciter field. The AVR responds to a voltage sensing signal derived from the main stator winding. By controlling the low power of the exciter field, control of the high power requirement of the main field is achieved through the rectified output of the exciter armature.

The SX440 AVR senses average voltage on two phases ensuring close regulation. In addition it detects engine speed and provides voltage fall off with speed, below a pre-selected speed (Hz) setting, preventing over-excitation at low engine speeds and softening the effect of load switching to relieve the burden on the engine.

The SX421 AVR in addition to the SX440 features has three phase rms sensing and also provides for over voltage protection when used in conjunction with an external circuit breaker (switchboard mounted).

### 2.2 PERMANENT MAGNET GENERATOR (PMG)

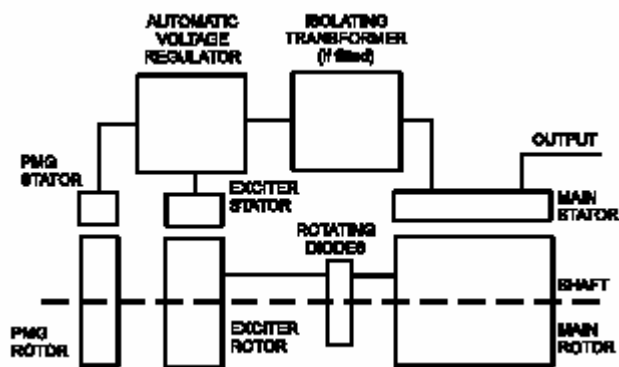

### EXCITED - AVR CONTROLLED GENERATORS

**Fig. 2**

The permanent magnet generator (PMG) provides power for excitation of the exciter field via the AVR MX341 (or MX321) which is the controlling device governing the level of excitation

provided to the exciter field. The AVR responds to a voltage sensing signal derived, via an isolating transformer in the case of MX321 AVR,

from the main stator winding. By controlling the low power of the exciter field, control of the high power requirement of the main field is achieved through the rectified output of the exciter armature.

The PMG system provides a constant source of excitation power irrespective of main stator loading and provides high motor starting capability as well as immunity to waveform distortion on the main stator output created by non linear loads, e.g. thyristor controlled dc motor.

The MX341 AVR senses average voltage on two phases ensuring close regulation. In addition it detects engine speed and provides an adjustable voltage fall off with speed, below a pre-selected speed (Hz) setting, preventing over-excitation at low engine speeds and softening the effect of load switching to relieve the burden on the engine. It also provides over-excitation protection which acts following a time delay, to de-excite the generator in the event of excessive exciter field voltage.

The MX321 provides the protection and engine relief features of the MX341 and additionally incorporates 3 phase rms sensing and over-voltage protection. The detailed function of all the AVR circuits is covered in the load testing section (subsection 4.7).

### 2.3 AVR ACCESSORIES

The SX440, SX421, MX341 and MX321 AVRs incorporate circuits which, when used in conjunction with accessories, can provide for parallel operation either with 'droop' or 'astatic' control, VAR/PF control and in the case of the MX321 AVR, short circuit current limiting.

Function and adjustment of the accessories which can be fitted inside the generator terminal box are covered in the accessories section of this book.

Separate instructions are provided with other accessories available for control panel mounting.

# SECTION 3

## APPLICATION OF THE GENERATOR

The generator is supplied as a component part for installation in a generating set. It is not, therefore, practicable to fit all the necessary warning/hazard labels during generator manufacture. The additional labels required are packaged with this Manual, together with a drawing identifying their locations. (see below).

It is the responsibility of the generating set manufacturer to ensure that the correct labels are fitted, and are clearly visible.

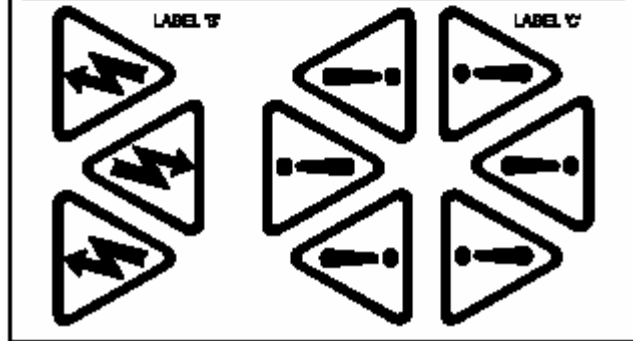
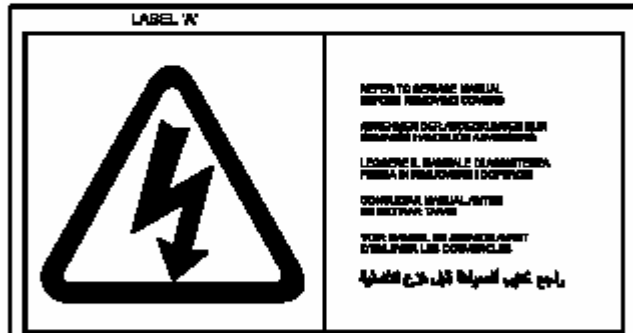
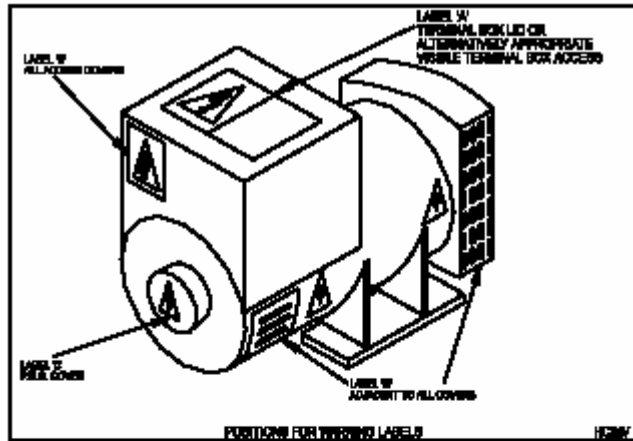

The generators have been designed for use in a maximum ambient temperature of 40°C, and altitude less than 1000 metres above sea level in accordance with BS5000.

Ambients in excess of 40°C, and altitudes above 1000 metres can be tolerated with reduced ratings - refer to the generator nameplate for rating and ambient.

In the event that the generator is required to operate in an ambient in excess of the nameplate value or at altitudes in excess of 1000 metres above sea level, refer to the factory.

The generators are of air-ventilated screen protected drip-proof design and are not suitable for mounting outdoors unless adequately protected by the use of canopies. Anti-condensation heaters are recommended during storage and for standby duty to ensure winding insulation is maintained in good condition.

When installed in a closed canopy it must be ensured that the ambient temperature of the cooling air to the generator does not exceed that for which the generator has been rated. The canopy should be designed such that the engine air intake to the canopy is separated from the generator intake, particularly where the radiator cooling fan is required to draw air into the canopy. In addition the generator air intake to the canopy should be designed such that the ingress of moisture is prohibited, preferably by use of a two stage filter.

The air intake/outlet must be suitable for the air flow given in the following table with additional pressure drops less than or equal to those given below:

Frame	Air Flow		Additional (intake/outlet) Pressure Drop
	50Hz 1500 Rev/Min	60Hz 1800 Rev/Min	
HC4	0.48m³/sec	0.58m³/sec	6mm water gauge (0.25")
	1030cfm	1240cfm	
HCK4	0.68m³/sec	0.83m³/sec	6mm water gauge (0.25")
	1450cfm	1760cfm	
HC5	1.04m³/sec	1.31m³/sec	6mm water gauge (0.25")
	2202cfm	2708cfm	
HCK5	1.23m³/sec	1.59m³/sec	6mm water gauge (0.25")
	2615cfm	3366cfm	
HC6	1.62m³/sec	1.96m³/sec	6mm water gauge (0.25")
	3420cfm	4156cfm	
HC7	2.64m³/sec	3.17m³/sec	6mm water gauge (0.25")
	5600cfm	6720cfm	
HCK7	3.0m³/sec	3.71m³/sec	6mm water gauge (0.25")
	6550cfm	7860cfm	

Table 1

If specified at the time of ordering, HC6 and HC7 generators may be fitted with air filters. Air filters can be supplied factory fitted or as parts for up-fit for the HC4 and HC5 generators. These are oil charged gauze filters and require charging during installation.

**Important ! Reduction in cooling air flow or inadequate protection to the generator can result in damage and/or failure of windings.**

Dynamic balancing of the generator rotor assembly has been carried out during manufacture in accordance with BS 6861 Part 1 Grade 2.5 to ensure vibration limits of the generator are in accordance with BS 4999 Part 142.

The main vibration frequencies produced by the component generator are as follows:- :

4 pole	1500 rpm	25 Hz
	1800 rpm	30 Hz
6 pole	1000 rpm	16.7 Hz
	1200 rpm	20 Hz

### 3.1 VIBRATION

Vibrations generated by the engine are complex and contain harmonics of 1.5, 3, 5 or more times the fundamental frequency of vibration. The generator will be subjected to this vibration, which will result in the generator being subjected to vibration levels higher than those derived from the generator itself.

Newage generators are designed to withstand the vibration levels encountered on generating sets built to meet the requirements of ISO 8528-9 and BS5000-3. (Where ISO 8528 is taken to be broad band measurements and BS5000 refers to the predominant frequency of any vibrations on the generating set.)

#### DEFINITION OF BS5000 - 3

Generators shall be capable of continuously withstanding linear vibration levels with amplitudes of 0.25mm between 5Hz and 8Hz and velocities of 9.0mm/s rms between 8 Hz and 200 Hz when measured at any point directly on the carcass or main frame of the machine. These limits refer only to the predominant frequency of vibration of any complex waveform.

#### DEFINITION OF ISO 8528 - 9

ISO 8528-9 refers to a broad band of frequencies, the broad band is taken to be between 2 Hertz and 300 Hertz. The table below is an example from ISO 8528 - 9 (value 1). This simplified table lists the vibration limits by kVA range and speed for acceptable genset operation.

VIBRATION LEVELS AS MEASURED ON THE GENERATOR				
Engine Speed Min <sup>-1</sup>	SET OUTPUT KVA	VIBRATION DISPLACEMENT	VIBRATION VELOCITY	VIBRATION ACCELERATION
<b>4 POLE</b> 1500 rpm 50Hz 1800 rpm 60 Hz	=10 kVA	-	-	-
	>10 but =50 kVA	0.64	40	25
	>50 but =125 kVA	0.4	25	16
	>125 but =250 kVA	0.4	25	16
	>250 kVA	0.32	20	13
<b>6 POLE</b> 1000 rpm 50Hz 1200 rpm 60Hz	>250 but =1250 kVA	0.32	20	13
	>1250	0.29	18	11

The 'Broad band' is taken as 2 Hz – 300 Hz

Table 2

It is the responsibility of the generating set designer to ensure the alignment of the genset, stiffness of the bedframe and mountings are such that the vibration limits as defined above are met.

If the vibration levels of the generating set are not within the parameters quoted above :-

1. Consult the genset builder. The genset builder should address the genset design to reduce the vibration levels as much as possible.
2. Discuss, with Newage, the impact of not meeting the above levels on both bearing and generator life expectancy.

**Important ! Exceeding either of the above specifications will have a detrimental effect on the generating set and in particular on the life of the bearings. (See section on bearings). This will invalidate the generator warranty. If**

**you are in any doubt, contact Newage International Limited.**

In standby applications where the running time is limited and reduced life expectancy is accepted, higher levels than specified in BS5000 can be tolerated, up to a maximum of 18mm/sec.

Two bearing generators require a substantial bedplate with engine/generator mounting pads to ensure a good base for accurate alignment. Close coupling of engine to generator can increase the overall rigidity of the set. A flexible coupling, designed to suit the specific engine/generator combination, is recommended to minimise torsional effects.

Alignment of single bearing generators is critical and vibration can occur due to the flexing of the flanges between the engine and generator. A substantial bedplate with engine/generator mounting pads is required.

For the purposes of establishing set design the bending moment at the engine flywheel housing to generator adaptor interface should not exceed that given in the table below:-

FRAME	BENDING MOMENT
4/5	140 kgm. (1000ft.lbs.)
6/7	275 kgm. (2000ft.lbs.)

The maximum bending moment of the engine flange must be checked with the engine manufacturer.

Torsional vibrations occur in all engine-driven shaft systems and may be of a magnitude to cause damage at certain critical speeds. It is therefore necessary to consider the torsional vibration effect on the generator shaft and couplings.

It is the responsibility of the generator set manufacturer to ensure compatibility, and for this purpose drawings showing the shaft dimensions and rotor inertias are available for customers to forward to the engine supplier. In the case of single bearing generators coupling details are included.

**Important ! Torsional incompatibility and/or excessive vibration levels can cause damage or failure of generator and/or engine components**

The standard terminal box is arranged for cable entry on the right hand side looking from the non drive end of the generator. If specified at the time of order cable entry may be arranged on the opposite side.

The terminal box is constructed with removable panels for easy adaptation to suit specific glanding requirements. Within the terminal box there are insulated terminals for line and neutral connections and provision for earthing. Additional earthing points are provided on the generator feet.



**No earth connections are made on the generator and reference to site regulations for earthing must be made. Incorrect earthing or protection arrangements can result in personal injury or death.**

The neutral is NOT connected to the frame.

Fault current curves (decrement curves), together with generator reactance data, are available on request to assist

the system designer to select circuit breakers, calculate fault currents and ensure discrimination within the load network.



**Warning !**

**Incorrect installation, service or replacement of parts can result in severe personal injury or death, and/or equipment damage. Service personnel must be qualified to perform electrical and mechanical service.**

# SECTION 4

## INSTALLATION - PART 1

### 4.1 LIFTING



**Warning !**

**Incorrect lifting or inadequate lifting capacity can result in severe personal injury or equipment damage. MINIMUM LIFTING CAPACITY REQUIRED IS AS INDICATED ON THE LIFTING LABEL. Generator lifting lugs should not be used for lifting the complete generating set.**

Two lifting lugs are provided for use with a shackle and pin type lifting aid. A spreader with chains to ensure that the lift is vertical of suitable length and lifting capacity must be used. Lifting points are designed to position the craneage point as close to the centre of gravity of the generator as possible, but due to design restrictions it is not possible to guarantee that the generator frame will remain horizontal while lifting. Care is therefore needed to avoid personal injury or equipment damage. The correct lifting arrangement is shown on the label attached to the lifting lug. (See sample below).

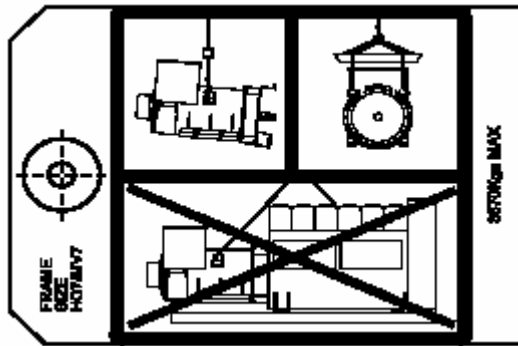

Fig. 3

Single bearing generators are supplied fitted with a rotor retaining bar at the drive end of the shaft. Single bearing generators are also fitted with wooden wedges supporting the fan for transit purposes.

Once the bar is removed to couple the rotor to engine, the rotor is free to move in the frame, and care is needed during coupling and alignment to ensure the frame is kept in the horizontal plane.

### 4.2 ENGINE TO GENERATOR COUPLING ASSEMBLY

During the assembly of the Generator to the Engine it will be necessary to firstly carefully align, then rotate, the combined Generator rotor - Engine crankshaft assembly, as part of the construction process, to allow location, insertion and tightening of the coupling bolts. This requirement to rotate the combined assemblies exists for both single and two bearing units.

During the construction of single bearing units it is necessary to align the generator's coupling holes with the engine flywheel holes: it is suggested that two diametrically opposite location dowel pins are fitted to the engine flywheel, over which the generator coupling can slide into final location into the engine flywheel spigot recess. The dowels must be

removed and replaced by coupling bolts before the final bolt tightening sequence.

While fitting and tightening the coupling bolts it will be necessary to rotate the Engine crankshaft - Generator rotor assembly. Care should be taken to ensure that rotation is carried out in an approved manner that ensures safe working practice when reaching inside the machine to insert or tighten coupling bolts, and that no component of the assembly is damaged by nonapproved methods of assembly rotation.

Engine Manufacturers have available a proprietary tool designed to enable manual rotation of the crankshaft assembly. This tool must always be used, having been engineered as an approved method of assembly rotation, by engaging the manually driven pinion with the engine flywheel starter ring-gear.



**Danger !**

**Before working inside the generator, during the aligning and fitting of coupling bolts, care should be taken to lock the assembly to ensure there is no possibility of assembly rotational movement.**

### 4.2.1 TWO BEARING GENERATORS

A flexible coupling should be fitted and aligned in accordance with the coupling manufacturer's instruction.

If a close coupling adaptor is used the alignment of machined faces must be checked by offering the generator up to the engine. Shim the generator feet if necessary. Ensure adaptor guards are fitted after generator/engine assembly is complete. Open coupled sets require a suitable guard, to be provided by the set builder.

Axial loading of the generator bearings should be avoided. Should it be unavoidable contact the factory for advice.

**Caution !** **Incorrect guarding and/or generator alignment can result in personal injury and/or equipment damage.**

### 4.2.2 SINGLE BEARING GENERATORS TYPES HC & HCK

For transit and storage purposes the generator frame spigot and rotor coupling plates have been coated with a rust preventative. This **MUST BE** removed before assembly to engine.

A practical method for removal of this coating is to clean the mating surface areas with a de-greasing agent based on a petroleum solvent.

**Caution !** **Care should be taken not to allow any cleaning agent to come into prolonged contact with skin.**

Alignment of single bearing generators is critical. If necessary shim the generator feet to ensure alignment of the machined surfaces.

The sequence of assembly to the engine should generally be as follows :

1. On the engine check the distance from the coupling mating face on the flywheel to the flywheel housing mating face. This should be within 0.5mm of nominal dimension. This is necessary to ensure that a thrust is not applied to the ac generator bearing or engine bearing.
2. Check that the bolts securing the flexible plates to the coupling hub are tight and locked into position. Refer to Section 7, subsection 7.5.3.4 for tightening torques.
3. Remove covers from the drive end of the generator to gain access to coupling and adaptor bolts. Check coupling joint interfaces are clean and lubricant free.

#### 4. TYPE HC GENERATORS

Check that coupling discs are concentric with adaptor spigot. This can be adjusted by the use of tapered wooden wedges between the fan and adaptor. Alternatively the rotor can be suspended by means of a rope sling through the adaptor opening.

Offer the generator to engine and engage both coupling discs and housing spigots at same time, pushing generator towards engine until coupling discs are against flywheel face, and housing spigots located.

#### TYPE HCK GENERATORS

Screw the two supplied location studs into diametrically opposite engine flywheel tapped holes, about the horizontal centre line. Offer the generator to engine, locating rotor coupling discs over the location studs, pushing generator towards engine until housing spigots locate and coupling discs are against flywheel face.

5. Fit housing and coupling bolts taking care to use heavy gauge washers between coupling bolt head and coupling disc. Tighten bolts evenly around assembly sufficiently to ensure correct alignment.

#### TYPE HCK GENERATORS

Remove location studs and replace with coupling flywheel bolts.

6. Tighten housing bolts.
7. Tighten coupling disc to flywheel bolts. Refer to engine manufacturers manual for correct tightening torque.

#### 8. TYPE HC GENERATORS

Remove rotor aligning aids, either wooden wedges, or the two M10 set screws and sheet metal wear plates.

**Incorrect guarding and/or generator alignment can result in personal injury and/or equipment damage.**

### 4.3 EARTHING

The generator frame should be solidly bonded to the generating set bedplate. If antivibration mounts are fitted between the generator frame and its bedplate a suitably rated earth conductor (normally one half of the cross sectional area

of the main line cables) should bridge across the antivibration mount.

**Refer to local regulations to ensure that the correct earthing procedure has been followed.**

### 4.4 PRE-RUNNING CHECKS

#### 4.4.1 INSULATION CHECK

Insulation tests should be carried out before running the generating set, both after assembly and after installation on site. (see Section 7.1).

**Important ! The windings have been H.V. tested during manufacture and further H.V. testing may degrade the insulation with consequent reduction in operating life. Should it be necessary to demonstrate H.V. testing, for customer acceptance, the tests must be carried out at reduced voltage levels i.e. Test Voltage= 0.8 (2 X Rated Voltage + 1000)**

#### 4.4.2 DIRECTION OF ROTATION

##### 4.4.2.1 FAN TYPES.

##### TYPE HC 4 & 5 GENERATORS.

These machines are fitted with a radial bladed bi-directional fan, operating within a conventional full height air outlet grills.

##### TYPE HC 6 & 7 GENERATORS.

These machines are fitted with an inclined bladed fan , operating within a conventional full height air outlet grills.

##### TYPE HCK 4, 5, & 7 GENERATORS.

These machines are fitted with a inclined bladed fan, operating within a voluted drive end adaptor with outlet grills half the machine height . Designed to optimise the fans performance.

##### 4.4.2.2 DIRECTION OF ROTATION

##### TYPE HCK GENERATORS.

These machines have been designed with an improved cooling fan system, incorporating the voluted fan housing. Therefore these machines are suitable only for clockwise rotation, as viewed from the drive end.

##### TYPE HC GENERATORS.

These machines can be operated in either direction of rotation.

##### Phase Rotation

HC generators can rotate efficiently in either direction. However phase rotation is fixed for clockwise rotation as viewed from the drive end. If the generator is to be rotated in a counter-clockwise direction it will be necessary for the customers to adjust their cabling to the output terminals accordingly. Refer to the factory for a reverse wiring diagram.

#### 4.4.3 VOLTAGE AND FREQUENCY

Check that the voltage and frequency levels required for the generating set application are as indicated on the generator nameplate. HC4/5 generators normally have a 12 ends out reconnectable winding. If it is necessary to reconnect the

stator for the voltage required, refer to diagrams in the back of this manual.

#### **4.4.4 AVR SETTINGS**

To make AVR selections and adjustments remove the AVR cover and refer to 4.4.4.1, 4.4.4.2, 4.4.4.3 or 4.4.4.4 depending upon type of AVR fitted. Reference to the generator nameplate will indicate AVR type (SX440, SX421, MX341 or MX321).

Most of the AVR adjustments are factory set in positions which will give satisfactory performance during initial running tests. Subsequent adjustment may be required to achieve optimum performance of the set under operating conditions. Refer to 'Load Testing' section for details.

#### 4.4.4.1 TYPE SX440 AVR

The following 'jumper' connections on the AVR should be checked to ensure they are correctly set for the generating set application.

Refer to Fig. 4a for location of selection links.

##### 1. Frequency selection terminals

50Hz operation LINK C-50  
60Hz operation LINK C-60

##### 2. Stability selection terminals

Frame HC4/5 LINK B-C  
Frame HC6/7 LINK A-B

##### 3. Sensing selection terminals

LINK 2-3  
LINK 4-5  
LINK 6-7

##### 4. Excitation Interruption Link

LINK K1-K2

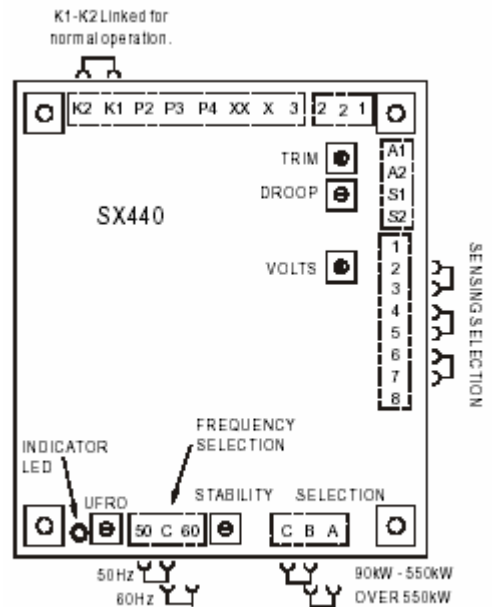

Fig. 4a

#### 4.4.4.2 TYPE SX421 AVR

The following 'jumper' connections on the AVR should be checked to ensure they are correctly set for the generating set application.

Refer to Fig. 4b for location of selection links.

##### 1. Frequency selection terminals

50Hz operation LINK C-50  
60Hz operation LINK C-60

##### 2. Stability selection terminals

Frame HC4/5 LINK B-C  
Frame HC6/7 LINK A-B

##### 3. Excitation Interruption Link

Linked at auxiliary terminal block. K1-K2

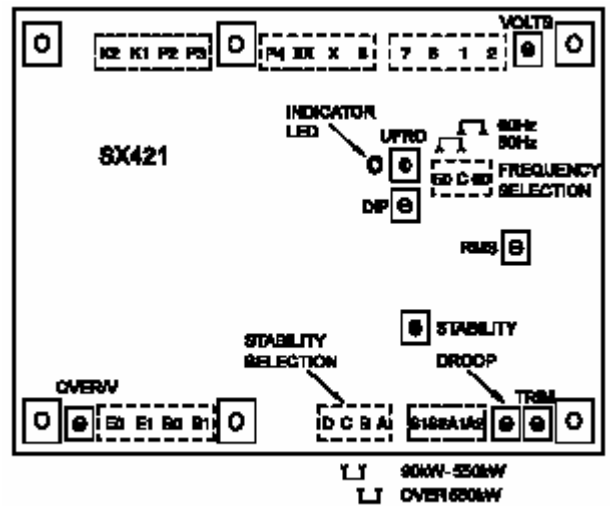

Fig. 4b

#### 4.4.4.3 TYPE MX341 AVR

The following 'jumper' connections on the AVR should be checked to ensure they are correctly set for the generating set application.

Refer to Fig. 4c for location of selection links.

4 pole 50Hz operation LINK 2-3  
4 pole 60Hz operation LINK 1-3  
6 pole 50Hz operation NO LINK  
6 pole 60Hz operation LINK 1-2

##### 2. Stability selection terminals

Frame HC4/5 LINK B-C  
Frame HC6/7 LINK A-B

##### 3. Sensing selection terminals

LINK 2-3  
LINK 4-5  
LINK 6-7

##### 4. Excitation Interruption Link

LINK K1-K2

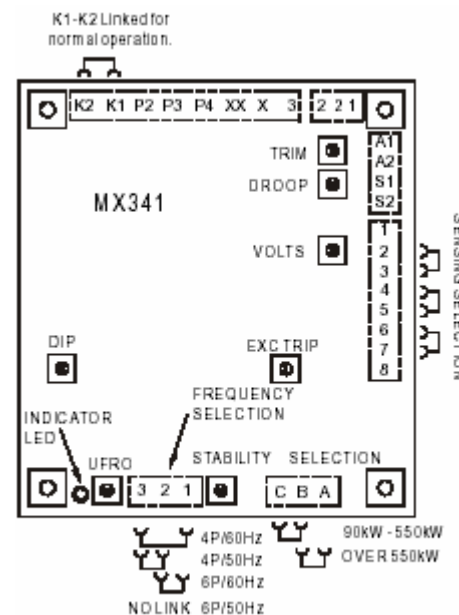

Fig. 4c

#### 4.4.4.4 TYPE MX321 AVR

The following 'jumper' connections on the AVR should be checked to ensure they are correctly set for the generating set application.

Refer to Fig. 4d for location of selection links.

#### 1. Frequency selection terminals

4 pole	50Hz operation	LINK 2-3
4 pole	60Hz operation	LINK 1-3
6 pole	50Hz operation	NO LINK
6 pole	60Hz operation	LINK 1-2

#### 2. Stability selection terminals

Frame HC4/5	LINK B-C
Frame HC6/7	LINK A-B

#### 3. Excitation Interruption Link

Linked at auxiliary terminal block. K1-K2

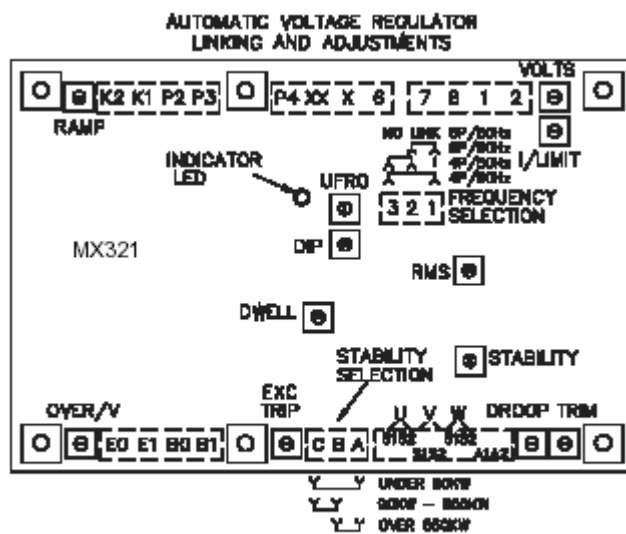

Fig. 4d

#### 4.5 GENERATOR SET TESTING



**Warning !**

During testing it may be necessary to remove covers to adjust controls exposing 'live' terminals or components. Only personnel qualified to perform electrical service should carry out testing and/or adjustments.

#### 4.5.1 TEST METERING/CABLING

Connect any instrument wiring and cabling required for initial test purposes with permanent or spring-clip type connectors. Minimum instrumentation for testing should be line - line or line to neutral voltmeter, Hz meter, load current metering and kW meter. If reactive load is used a power factor meter is desirable.

**Important !** When fitting power cables for load testing purposes, ensure cable voltage rating is at least equal to the generator rated voltage. The load cable termination should be placed on top of the winding lead termination and clamped between the two nuts provided, on HC4/5 generators.

**Caution !**

Check that all wiring terminations for internal or external wiring are secure, and fit all terminal box covers and guards. Failure to secure wiring and/or covers may result in personal injury and/or equipment failure.

#### 4.6 INITIAL START-UP



**Warning !**

During testing it may be necessary to remove covers to adjust controls exposing 'live' terminals or components. Only personnel qualified to perform electrical service should carry out testing and/or adjustments. Refit all access covers after adjustments are completed.

On completion of generating set assembly and before starting the generating set ensure that all engine manufacturer's prunning procedures have been completed, and that adjustment of the engine governor is such that the generator will not be subjected to speeds in excess of 125% of the rated speed.

**Important !** Overspeeding of the generator during initial setting of the speed governor can result in damage to the generator rotating components.

In addition remove the AVR access cover and turn VOLTS control fully anti-clockwise. Start the generating set and run on no-load at nominal frequency. Slowly turn VOLTS control potentiometer clockwise until rated voltage is reached. Refer to Fig. 4a - 4d for control potentiometer location.

**Important !** Do not increase the voltage above the rated generator voltage shown on the generator nameplate.

The STABILITY control potentiometer will have been pre-set and should normally not require adjustment, but should this be required, usually identified by oscillation of the voltmeter, refer to Fig. 4a - 4d for control potentiometer location and proceed as follows:-

1. Run the generating set on no-load and check that speed is correct and stable.
2. Turn the STABILITY control potentiometer clockwise, then turn slowly anti-clockwise until the generator voltage starts to become unstable.

The correct setting is slightly clockwise from this position (i.e. where the machine volts are stable but close to the unstable region).

## 4.7 LOAD TESTING



**Warning !**

During testing it may be necessary to remove covers to adjust controls exposing 'live' terminals or components. Only personnel qualified to perform electrical service should carry out testing and/or adjustments. Refit all access covers after adjustments are completed.

### 4.7.1 AVR ADJUSTMENTS

Refer to Fig. 4a - 4d for control potentiometer locations. Having adjusted VOLTS and STABILITY during the initial startup procedure, other AVR control functions should not normally need adjustment. If instability on load is experienced recheck stability setting. Refer to subsection 4.6.

If however, poor voltage regulation on-load or voltage collapse is experienced, refer to the following paragraphs on each function to a) check that the symptoms observed do indicate adjustment is necessary, and b) to make the adjustment correctly.

#### 4.7.1.1 UFRO (Under Frequency Roll Off) (AVR Types SX440, SX421, MX341 and MX321)

The AVR incorporates an underspeed protection circuit which gives a voltage/speed (Hz) characteristic as shown :

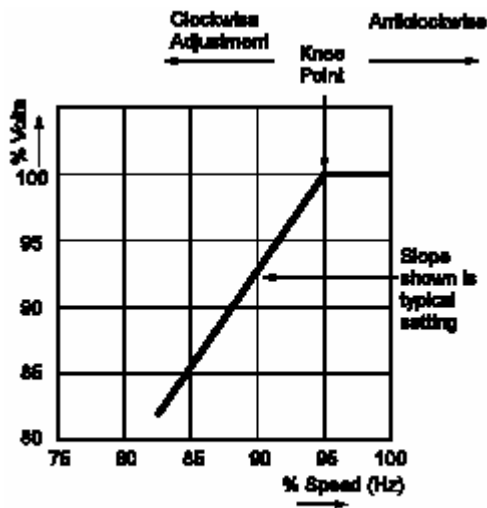

**Fig. 5**

The UFRO control potentiometer sets the "knee point".

Symptoms of incorrect setting are a) the light emitting diode (LED) indicator, just above the UFRO Control potentiometer, being permanently lit when the generator is on load, and b) poor voltage regulation on load, i.e. operation on the sloping part of the characteristic.

Clockwise adjustment lowers the frequency (speed) setting of the "knee point" and extinguishes the LED. For Optimum setting the LED should illuminate as the frequency falls just below nominal frequency, i.e. 47Hz on a 50Hz generator or 57Hz on a 60Hz generator.

**Important !** With AVR Types MX341 and MX321. If the LED is illuminated and no output voltage is present, refer to EXC TRIP and/or OVER/V sections below.

#### 4.7.1.2 EXC TRIP (Excitation Trip) AVR Types MX341 and MX321

An AVR supplied from a permanent magnet generator inherently delivers maximum excitation power on a line to line or line to neutral short circuit. In order to protect the generator windings the AVR incorporates an over excitation circuit which detects high excitation and removes it after a pre-determined time, i.e. 8-10 seconds.

Symptoms of incorrect setting are the generator output collapses on load or small overload, and the LED is permanently illuminated.

The correct setting is 70 volts +/- 5% between terminals X and XX.

#### 4.7.1.3 OVER/V (Over Voltage) AVR Types SX421 and MX321

Over voltage protection circuitry is included in the AVR to remove generator excitation in the event of loss of AVR sensing input.

The MX321 has both internal electronic de-excitation and provision of a signal to operate an external circuit breaker. The SX421 only provides a signal to operate an external breaker, which MUST be fitted if over voltage protection is required. Incorrect setting would cause the generator output voltage to collapse at no-load or on removal of load, and the LED to be illuminated.

The correct setting is 300 volts +/-5% across terminals E1, E0.

Clockwise adjustment of the OVER/V control potentiometer will increase the voltage at which the circuit operates.

#### 4.7.1.4 TRANSIENT LOAD SWITCHING ADJUSTMENTS AVR Types SX421, MX341 and MX321

The additional function controls of DIP and DWELL are provided to enable the load acceptance capability of the generating set to be optimised. The overall generating set performance depends upon the engine capability and governor response, in conjunction with the generator characteristics.

It is not possible to adjust the level of voltage dip or recovery independently from the engine performance, and there will always be a 'trade off' between frequency dip and voltage dip.

## DIP-AVR Types SX421, MX341 and MX321

The dip function control potentiometer adjusts the slope of the voltage/speed (Hz) characteristic below the knee point as shown below:

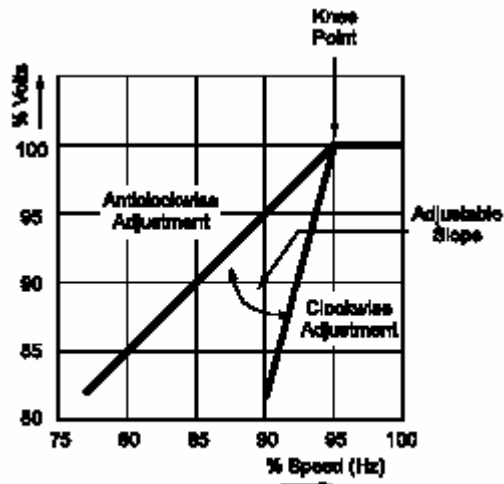

Fig. 6

## DWELL-AVR Type MX321

The dwell function introduces a time delay between the recovery of voltage and recovery of speed.

The purpose of the time delay is to reduce the generator kW below the available engine kW during the recovery period, thus allowing an improved speed recovery.

Again this control is only functional below the "knee point", i.e. if the speed stays above the knee point during load switching there is no effect from the DWELL function setting.

Clockwise adjustment gives increased recovery time.

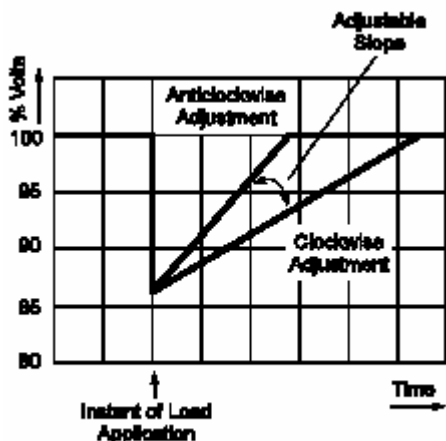

Fig. 7

The graphs shown above are representations only, since it is impossible to show the combined effects of voltage regulator and engine governor performance.



Failure to refit covers can result in operator personal injury or death.

Warning !

## 4.7.1.5 RAMP AVR Type MX321

The RAMP potentiometer enables adjustment of the time taken for the generator's initial build up to normal rated voltage during each start and run up to speed. The potentiometer is factory set to give a ramp time of three seconds, which is considered to be suitable for most applications. This time can be reduced to one second by turning the pot. fully counter clockwise, and increased to eight seconds by turning the pot. fully clockwise.

## 4.8 ACCESSORIES

Refer to the "ACCESSORIES" Section of this Manual for setting up procedures related to generator mounted accessories.

If there are accessories for control panel mounting supplied with the generator refer to the specific accessory fitting procedures inserted inside the back cover of this book.

Replace AVR access cover after all adjustments are completed.

# SECTION 5

## INSTALLATION - PART 2

### 5.1 GENERAL

The extent of site installation will depend upon the generating set build, e.g. if the generator is installed in a canopied set with integral switchboards and circuit breaker, on site installation will be limited to connecting up the site load to the generating set output terminals. In this case reference should be made to the generating set manufacturer's instruction book and any pertinent local regulations.

If the generator has been installed on a set without switchboard or circuit breaker the following points relating to connecting up the generator should be noted.

### 5.2 GLANDING

The terminal box is arranged for glanding on the right hand side (or if specifically ordered on the left hand side) viewed from the non drive end. Both panels are removable for drilling/punching to suit glands/or glanding boxes. If single core cables are taken through the terminal box side panel an insulated or non-magnetic gland plate should be fitted.

At entry to the terminal box incoming cables should be supported by a recognised glanding method such that minimum unsupported weight, and no axial force is transferred to the terminal assembly.

Incoming cables external to the terminal box should be supported at a sufficient distance from the centre line of the generating set so as to avoid a tight radius at the point of entry into the terminal box panel, and allow movement of the generator set on its anti-vibration mountings without excessive stress on the cable.

Before making final connections, test the insulation resistance of the windings. The AVR should be disconnected during this test and RTD leads grounded.

A 500V Megger or similar instrument should be used. Should the insulation resistance be less than  $5M\Omega$  the windings must be dried out as detailed in the Service and Maintenance section of this manual.

When making connections to the terminals of Frame 4 generators, the incoming cable termination lug should be placed on top of the winding lead termination lug(s) and then clamped with the nut provided.

**Important ! To avoid the possibility of swarf entering any electrical components in the terminal box, panels must be removed for drilling.**

### 5.3 TORQUE SETTINGS FOR TERMINAL CONNECTIONS

**Pre treatment:** Clean plated surfaces with a degreasing agent, then lightly abrade them to remove any tarnish. Don't score the surface.

The **generator torque settings** for all connections, links, CT's, accessories, cables, etc. is 45 Nm.

The **customer output cables** should be connected to the terminals using 8.8 grade steel bolts and associated antivibration hardware.

The following table is for your guidance.

FRAME	HOLE SIZE	BOLT SIZE	TORQUE Nm
4	-	12	45
5	13	12	50
6	17	14	70
7	17	16	90

Table 3

Carry out **periodic checks** to ensure the correct torque settings.

### 5.4 EARTHING

The neutral of the generator is not bonded to the generator frame as supplied from the factory. An earth terminal is provided inside the terminal box adjacent to the main terminals. Should it be required to operate with the neutral earthed a substantial earth conductor (normally equivalent to one half of the section of the line conductors) must be connected between the neutral and the earth terminal inside the terminal box. It is the responsibility of the generating set builder to ensure the generating set bedplate and generator frame are all bonded to the main earth terminal in the terminal box.

**Reference to local electricity regulations  
Caution ! or safety rules should be made to ensure  
correct earthing procedures have been  
followed.**

### 5.5 PROTECTION

It is the responsibility of the end user and his contractors/subcontractors to ensure that the overall system protection meets the needs of any inspectorate, local electricity authority or safety rules, pertaining to the site location. To enable the system designer to achieve the necessary protection and/or discrimination, fault current curves are available on request from the factory, together with generator reactance values to enable fault current calculations to be made.



**Warning !**

**Incorrect installation and/or protective systems can result in personal injury and/or equipment damage. Installers must be qualified to perform electrical installation work.**

### 5.6 COMMISSIONING

Ensure that all external cabling is correct and that all the generating set manufacturer's pre-running checks have been carried out before starting the set.

Generators fitted with air filters should have the filters charged with oil prior to commissioning. Refer to Service Section for charging procedure (subsection 7.3.2).

The generator AVR controls will have been adjusted during the generating set manufacturer's tests and should normally not require further adjustment.

Should malfunction occur during commissioning refer to Service and Maintenance section 'Fault Finding' procedure (subsection 7.4).

# SECTION 6

## ACCESSORIES

Generator control accessories may be fitted, as an option, in the generator terminal box. If fitted at the time of supply, the wiring diagram(s) in the back of this book shows the connections. When the options are supplied separately, fitting instructions are provided with the accessory.

The following table indicates availability of accessories with the differing AVRs.

AVR Model	Paralleling Droop or Astatic	Manual Voltage Regulator	Var/PF Control	Current Limit
SX440	3	7	3	7
SX421	3	7	3	7
MX341	3	3	3	7
MX321	3	3	3	3

### 6.1 REMOTE VOLTAGE ADJUST (ALL AVR TYPES)

A remote voltage adjust (hand trimmer) can be fitted.

The remote voltage adjustment potentiometer is connected across AVR terminals 1-2.

These terminals are normally linked.

When the remote voltage adjust potentiometer is used the link across terminals 1-2 must be removed.

On AVR types SX440 and MX341 the link 1-2 is on an adjacent terminal block.

On AVR types SX421 and MX321 the link 1-2 is on the AVR terminals.

### 6.2 PARALLEL OPERATION

Understanding of the following notes on parallel operation is useful before attempting the fitting or setting of the droop kit accessory. When operating in parallel with other generators or the mains, it is essential that the phase sequence of the incoming generator matches that of the busbar and also that all of the following conditions are met before the circuit breaker of the incoming generator is closed on to the busbar (or operational generator).

1. Frequency must match within close limits.
2. Voltages must match within close limits.
3. Phase angle of voltages must match within close limits.

A variety of techniques, varying from simple synchronising lamps to fully automatic synchronisers, can be used to ensure these conditions are met.

Once connected in parallel a minimum instrumentation level per generator of voltmeter, ammeter, wattmeter (measuring total power per generator), and frequency meter is required in order to adjust the engine and generator controls to share kW in relation to engine ratings and kVAr in relation to generator ratings.

**Important ! Failure to meet conditions 1, 2, and 3 when closing the circuit breaker, will generate excessive mechanical and electrical stresses, resulting in equipment damage.**

It is important to recognise that

1. kW are derived from the engine, and speed governor characteristics determine the kW sharing between sets
- and
2. kVAr are derived from the generator, and excitation control characteristics determine the kVAr sharing.

Reference should be made to the generating set manufacturer's instructions for setting the governor controls.

#### 6.2.1 DROOP

The most commonly used method of kVAr sharing is to create a generator voltage characteristic which falls with decreasing power factor (increasing kVAr). This is achieved with a current transformer (C.T.) which provides a signal dependent on current phase angle (i.e. power factor) to the AVR.

The current transformer has a burden resistor on the AVR board, and a percentage of the burden resistor voltage is summed into the AVR circuit. Increasing droop is obtained by turning the DROOP control potentiometer clockwise.

The diagrams below indicate the effect of droop in a simple two generator system :-

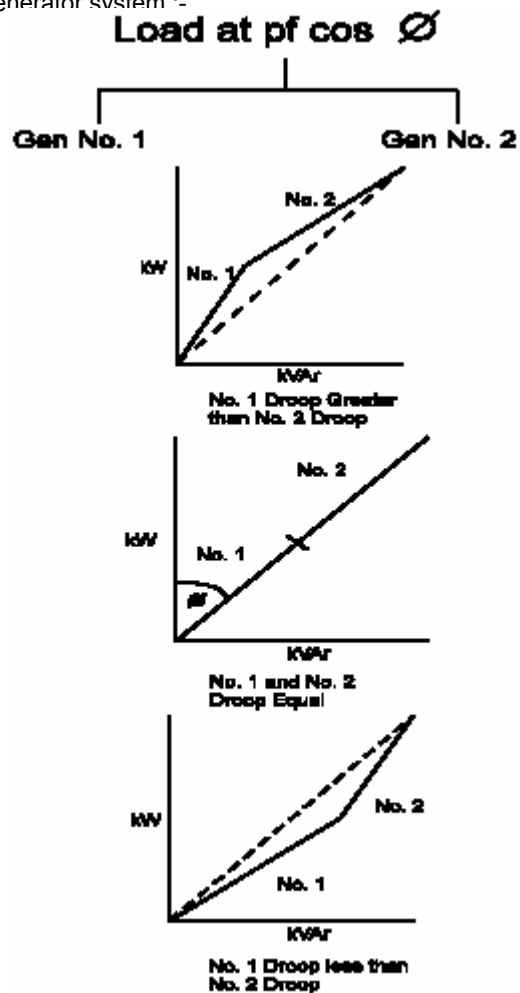

**Fig. 8**

Generally 5% droop at full load current zero p.f. is sufficient to ensure kVAr sharing.

If the droop accessory has been supplied with the generator it will have been tested to ensure correct polarity and set to a nominal level of droop. The final level of droop will be set during generating set commissioning.

Although nominal droop setting may be factory set it is advisable to go through the setting procedure below.

### 6.2.1.1 SETTING PROCEDURE

Depending upon available load the following settings should be used - all are based on rated current level.

0.8 P.F. LOAD (at full load current) SET DROOP TO 3%  
Zero P.F. LOAD (at full load current) SET DROOP TO 5%

Setting the droop with low power factor load is the most accurate.

Run each generator as a single unit at rated frequency or rated frequency + 4% depending upon type of governor and nominal voltage. Apply available load to rated current of the generator. Adjust 'DROOP' control potentiometer to give droop in line with above table. Clockwise rotation increases amount of droop. Refer to Fig. 4a - 4d for potentiometer locations.

Note 1)

Reverse polarity of the C.T. will raise the generator voltage with load. The polarities S1-S2 shown on the wiring diagrams are correct for clockwise rotation of the generator looking at the drive end. Reversed rotation requires S1-S2 to be reversed.

Note 2)

The most important aspect is to set all generators equal. The precise level of droop is less critical.

Note 3)

A generator operated as a single unit with a droop circuit set at rated load 0.8 power factor is unable to maintain the usual 0.5% regulation. A shorting switch can be connected across S1-S2 to restore regulation for single running.

**Important ! LOSS OF FUEL to an engine can cause its generator to motor with consequent damage to the generator windings. Reverse power relays should be fitted to trip main circuit breaker.**

**LOSS OF EXCITATION to the generator can result in large current oscillations with consequent damage to generator windings. Excitation loss detection equipment should be fitted to trip main circuit breaker.**

### 6.2.2 ASTATIC CONTROL

The 'droop' current transformer can be used in a connection arrangement which enables the normal regulation of the generator to be maintained when operating in parallel.

This feature is only supplied from the factory as a fitted droop kit, however, if requested at the time of order, the diagrams inside the back cover of this book will give the necessary site connections. The end user is required to provide a shorting switch for the droop current transformer secondary.

**Important ! When using this connection arrangement a shorting switch is required across each C.T. burden (terminals S1 and S2.) The switch must be closed a) when a generating set is not running and b) when a generating set is selected for single running.**

Should the generator be required to be converted from standard droop to 'astatic' control, diagrams are available on request.

The setting procedure is exactly the same as for DROOP. (Subsection 6.2.1.1)

### 6.3 MANUAL VOLTAGE REGULATOR (MVR)-MX341 and MX321 AVR

This accessory is provided as an 'emergency' excitation system, in the event of an AVR failure.

Powered from a PMG output the unit is manually set, but automatically controls the excitation current, independent of generator voltage or frequency.

The unit is provided with 'MANUAL', 'OFF', 'AUTO' switching facility.

#### 'MANUAL'

- position connects the exciter field to the MVR output. Generator output is then controlled by the operator adjusting the excitation current.

#### 'OFF'

- disconnects the exciter field from both MVR and the normal AVR.

#### 'AUTO'

- connects the exciter field to the normal AVR and the generator output is controlled at the pre-set voltage under AVR control.

### 6.4 OVERVOLTAGE DE-EXCITATION BREAKER SX421 and MX321 AVR

This accessory provides positive interruption of the excitation power in the event of overvoltage due to loss of sensing or internal AVR faults including the output power device.

With the MX321 AVR this accessory is supplied loose for fitting in the control panel.

In the case of the SX421 the circuit breaker is always supplied and will normally be fitted in the generator.

**Important !** When the CB is supplied loose, terminals K1-K2 at the auxiliary terminal block are fitted with a link to enable operation of the AVR. When connecting the circuit breaker this link must be removed.

#### 6.4.1 RESETTING THE EXCITATION BREAKER

In the event of operation of the circuit breaker, indicated by loss of generator output voltage, manual resetting is required. When in the "tripped" state the circuit breaker switch lever shows "OFF". To reset move the switch lever to the position showing "ON".

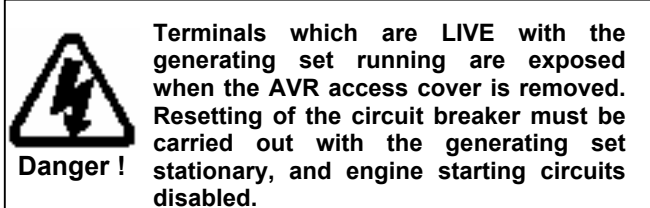

When fitted in the generator, access to the breaker is gained by removal of the AVR access cover. The circuit breaker is mounted on the AVR mounting bracket either to the left or to the right of the AVR depending upon AVR position. After resetting the circuit breaker replace the AVR access cover before restarting the generating set. Should resetting of the circuit breaker not restore the generator to normal operation, refer to subsection 7.5.

#### 6.5 CURRENT LIMIT - MX321 AVR

These accessories work in conjunction with the AVR circuits to provide an adjustment to the level of current delivered into a fault. One current transformer (CT) per phase is fitted to provide current limiting on any line to line or line to neutral fault. Note: The W phase CT can also provide "DROOP". Refer to 6.2.1.1. for setting droop independent of current limit. Adjustment means is provided with the "/LIMIT" control potentiometer on the AVR. Refer to Fig. 4d for location. If current limit transformers are supplied with the generator the limit will be set in accordance with the level specified at the time of order, and no further adjustment will be necessary. However, should the level need to be adjusted, refer to the setting procedure given in 6.5.1.

##### 6.5.1 SETTING PROCEDURE

Run the generating set on no-load and check that engine governor is set to control nominal speed.

Stop the generating set. Remove the link between terminals K1-K2 at the auxiliary terminal block and connect a 5A switch across the terminals K1-K2.

Turn the "/LIMIT" control potentiometer fully anticlockwise. Short circuit the stator winding with a bolted 3 phase short at the main terminals. An AC current clip-on ammeter is required to measure the winding lead current.

With the switch across K1-K2 open start the generating set.

Close the switch across K1-K2 and turn the "/LIMIT" control potentiometer clockwise until required current level is observed on the clip-on ammeter. As soon as correct setting is achieved open the K1-K2 switch.

Should the current collapse during the setting procedure, the internal protective circuits of the AVR will have operated. In this event shut down the set and open the K1-K2 switch. Restart the set and run for 10 minutes with K1-K2 switch open, to cool the generator windings, before attempting to resume the setting procedure.

**Important !** Failure to carry out the correct COOLING procedure may cause overheating and consequent damage to the generator windings.

#### 6.6 POWER FACTOR CONTROLLER (PFC3)

This accessory is primarily designed for those generator applications where operation in parallel with the mains supply is required.

Protection against loss of mains voltage or generator excitation is not included in the unit and the system designer must incorporate suitable protection.

The electronic control unit requires both droop and kVA<sub>r</sub> current transformers. When supplied with the generator, wiring diagrams inside the back cover of this manual show the connections and the additional instruction leaflet provided gives details of setting procedures for the power factor controller (PFC3).

The unit monitors the power factor of the generator current and adjusts excitation to maintain the power factor constant.

This mode can also be used to control the power factor of the mains if the point of current monitoring is moved to the mains cables. Refer to the factory for appropriate details.

It is also possible to operate the unit to control kVA<sub>r</sub> of the generator if required. Refer to the factory for appropriate details.

# SECTION 7

## SERVICE AND MAINTENANCE

As part of routine maintenance procedures, periodic attention to winding condition (particularly when generators have been idle for a long period) and bearings is recommended. (Refer to subsections 7.1 and 7.2 respectively).

When generators are fitted with air filters regular inspection and filter maintenance is required. (Refer to subsection 7.3).

### 7.1 WINDING CONDITION



**Warning !**

**Service and fault finding procedures present hazards which can result in severe personal injury or death. Only personnel qualified to perform electrical and mechanical service should carry out these procedures. Ensure engine starting circuits are disabled before commencing service or maintenance procedures. Isolate any anti-condensation heater supply.**

#### Guidance of Typical Insulation Resistance [IR] Values

The following is offered as general information about IR values and is aimed at providing guidance about the typical IR values for generators from new through to the point of refurbishment.

#### New Machines

The generators Insulation Resistance, along with many other critical factors, will have been measured during the alternator manufacturing process. The generator will have been transported with an appropriate packaging suitable for the method of delivery to the Generating Set assemblers works. Where we expect it to be stored in a suitable location protected from adverse environmental conditions.

However, absolute assurance that the generator will arrive at the Gen-set production line with IR values still at the factory test levels of above 100 MΩ cannot be guaranteed.

#### At Generating Set Manufacturers Works

The generator should have been transported and stored such that it will be delivered to the assembly area in a clean dry condition. If held in appropriate storage conditions the generator IR value should typically be 25 MΩ.

If the unused/new generators IR values fall below 10 MΩ then a drying out procedure should be implemented by one of the processes outlined below before being despatched to the end customer's site. Some investigation should be undertaken into the storage conditions of the generator while on site.

#### Generators in Service

Whilst it is known that a generator will give reliable service with an IR value of just 1.0 MΩ. For a relatively new generator to be so low it must have been subjected to inappropriate operating or storage conditions.

Any temporarily reduction in IR values can be restored to expected values by following one of the drying out procedures.

### 7.1.1 WINDING CONDITION ASSESSMENT

**The AVR should be disconnected and Caution ! the Resistance Temperature Detector (R.T.D.) leads grounded during this test.**

The condition of the windings can be assessed by measurement of insulation resistance [IR] between phase to phase, and phase to earth. Measurement of winding insulation should be carried out: -

1. As part of a periodic maintenance plan.
2. After prolonged periods of shutdown.
3. When low insulation is suspected, e.g. damp or wet windings.

Care should be taken when dealing with windings that are suspected of being excessively damp or dirty. The initial measurement of the [IR] Insulation Resistance should be established using a low voltage (500V) megger type instrument. If manually powered the handle should initially be turned slowly so that the full test voltage will not be applied, and only applied for long enough to very quickly assess the situation if low values are suspected or immediately indicated.

Full megger tests or any other form of high voltage test should not be applied until the windings have been dried out and if necessary cleaned.

#### Procedure for Insulation Testing

Disconnect all electronic components, AVR, electronic protection equipment etc. Ground the [RTD's] Resistance Temperature Detection devices if fitted. Short out the diodes on the rotating diode assembly. Be aware of all components connected to the system under test that could cause false readings or be damaged by the test voltage.

Carry out the insulation test in accordance with the 'operating instructions for the test equipment.

The measured value of insulation resistance for all windings to earth and phase to phase should be compared with the guidance given above for the various 'life stages' of a generator. The minimum acceptable value must be greater than 1.0 MΩ.

**If low winding insulation is confirmed use one or more of the methods, given below, for drying the winding should be carried out.**

### 7.1.2 METHODS OF DRYING OUT GENERATORS

#### Cold Run

Consider a good condition generator that has not been run for some time, and has been standing in damp, humid conditions. It is possible that simply running the gen set unexcited – AVR terminals K1 K2 open circuit - for a period of say 10 minutes will sufficiently dry the surface of the windings and raise the IR

sufficiently, to greater than 1.0 MΩ , and so allow the unit to be put into service.

### **Blown Air Drying**

Remove the covers from all apertures to allow the escape of the water-laden air. During drying, air must be able to flow freely through the generator in order to carry off the moisture.

Direct hot air from two electrical fan heaters of around 1 – 3 Kw into the generator air inlet apertures. Ensure the heat source is at least 300mm away from the windings to avoid over heating and damage to the insulation.

Apply the heat and plot the insulation value at half hourly intervals. The process is complete when the parameters covered in the section entitled, 'Typical Drying Out Curve', are met.

Remove the heaters, replace all covers and re-commission as appropriate.

If the set is not to be run immediately ensure that the anticondensation heaters are energised, and retest prior to running.

**Short Circuit Method**

NOTE: This process should only be performed by a competent engineer familiar with safe operating practices within and around generator sets of the type in question. Ensure the generator is safe to work on, initiate all mechanical and electrical safety procedures pertaining to the genset and the site.

Bolt a short circuit of adequate current carrying capacity, across the main terminals of the generator. The shorting link should be capable of taking full load current.

Disconnect the cables from terminals “X” and “XX” of the AVR.

Connect a variable dc supply to the “X” (positive) and “XX” (negative) field cables. The dc supply must be able to provide a current up to 2.0 Amp at 0 - 24 Volts.

Position a suitable ac ammeter to measure the shorting link current.

Set the dc supply voltage to zero and start the generating set. Slowly increase the dc voltage to pass current through the exciter field winding. As the excitation current increases, so the stator current in the shorting link will increase. This stator output current level must be monitored, and not allowed to exceed 80% of the generators rated output current.

After every 30 minutes of this exercise: Stop the generator and switch off the separate excitation supply, and measure and record the stator winding IR values, and plot the results. The resulting graph should be compared with the classic shaped graph. This drying out procedure is complete when the parameters covered in the section entitled 'Typical Drying Out Curve' are met.

Once the Insulation Resistance is raised to an acceptable level - minimum value 1.0 MΩ – the dc supply may be removed and the exciter field leads “X” and “XX” re-connected to their terminals on the AVR.

Rebuild the genset, replace all covers and re-commission as appropriate.

If the set is not to be run immediately ensure that the anticondensation heaters are energised, and retest the generator prior to running.

**TYPICAL DRYING OUT CURVE**

Whichever method is used to dry out the generator the resistance should be measured every half-hour and a curve plotted as shown. (fig 6.)

The illustration shows a typical curve for a machine that has absorbed a considerable amount of moisture. The curve

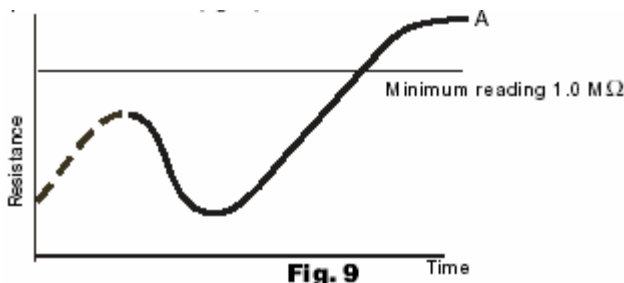

**Fig. 9**

indicates a temporary increase in resistance, a fall and then a gradual rise to a steady state. Point 'A', the steady state, must be greater than 1.0 MΩ. (If the windings are only slightly damp the dotted portion of the curve may not appear).

For general guidance expect that the typical time to reach point 'A' will be :

- 1 hour for a BC16/18,
- 2 hours for a UC22/27
- 3 hours for an HC4,5,6&7

Drying should be continued after point “A” has been reached for at least one hour.

It should be noted that as winding temperature increases, values of insulation resistance may significantly reduce. Therefore, the reference values for insulation resistance can only be established with windings at a temperature of approximately 20°C.

If the IR value remains below 1.0 MΩ, even after the above drying methods have been properly conducted, then a Polarisation Index test [PI] should be carried out.

If the minimum value of 1.0 MΩ for all components cannot be achieved rewinding or refurbishment of the generator will be necessary.

**The generator must not be put into service until the minimum values can be achieved.**

**Important ! The short circuit must not be applied with the AVR connected in circuit. Current in excess of the rated generator current will cause damage to the windings.**

After drying out, the insulation resistances should be rechecked to verify minimum resistances quoted above are achieved. On re-testing it is recommended that the main stator insulation resistance is checked as follows :-  
Separate the neutral leads

Ground V and W phase and megger U phase to ground  
Ground U and W phase and megger V phase to ground  
Ground U and V phase and megger W phase to ground  
If the minimum value of 1.0MΩ is not obtained, drying out must be continued and the test repeated.

**7.2 BEARINGS**

One of two bearing options will be fitted to generators covered by this manual.

Bearing Options		
HC/HCK/HCM	Regreasable*	Sealed for life*†
4	Not available	Standard
5	Optional	Standard
6	Optional	Standard
7	Standard	Not available

**Table 5**

\*All bearings are supplied pre-packed with Kluber Asonic GHY 72 grease.

†Sealed for life bearings are fitted with integral seals and are not regreasable.

**BEARING LIFE**

**Important !** The life of a bearing in service is subject to the working conditions and the environment.

**Important !** High levels of vibration from the engine or misalignment of the set will stress the bearing and reduce its service life. If the vibration limits set out in BS 5000-3 and ISO 8528-9 are exceeded bearing life will be reduced. Refer to 'Vibration' below.

**Important !** Long stationary periods in an environment where the generator is subject to vibration can cause false brinnelling, which puts flats on the ball and grooves on the races, leading to premature failure.

**Important ! Very humid atmospheric or wet conditions can emulsify the grease causing corrosion and deterioration of the grease, leading to premature failure of the bearings.**

**Important ! Exceeding either of the above specifications will have a detrimental effect on the life of the bearing. This will invalidate the generator warranty. If you are in any doubt, contact Newage International Limited.**

## HEALTH MONITORING OF THE BEARINGS

Newage recommends that the user checks the bearing condition, using monitoring equipment, to determine the state of the bearings. The 'best practice' is to take initial readings as a base line and periodically monitor the bearings to detect a deteriorating trend. It will then be possible to plan a bearing change at an appropriate generating set or engine service interval.

## VIBRATION

Newage generators are designed to withstand the vibration levels encountered on generating sets built to meet the requirements of ISO 8528-9 and BS5000-3. (Where ISO 8528 is taken to be broad band measurements and BS5000 refers to the predominant frequency of any vibrations on the generating set.)

### DEFINITION of BS5000 – 3

Generators shall be capable of continuously withstanding linear vibration levels with amplitudes of 0.25mm between 5Hz and 8Hz and velocities of 9.0mm/s rms between 8 Hz and 200 Hz when measured at any point directly on the carcass or main frame of the machine. These limits refer only to the predominant frequency of vibration of any complex waveform.

### DEFINITION of ISO 8528 - 9

ISO 8528-9 refers to a broad band of frequencies, the broad band is taken to be between 2 Hertz and 300 Hertz. The table below is an example from ISO 8528 - 9 (value 1). This simplified table lists the vibration limits by kVA range and speed for acceptable genset operation.

VIBRATION LEVELS AS MEASURED ON THE GENERATOR				
Engine Speed Min <sup>1</sup>	SET OUTPUT KVA	VIBRATION DISPLACEMENT	VIBRATION VELOCITY	VIBRATION ACCELERATION
<b>4 POLE</b> 1500 rpm 50Hz 1800 rpm 60 Hz	=10 kVA	-	-	-
	>10 but =50 kVA	0.64	40	25
	>50 but =125 kVA	0.4	25	16
	>125 but =250 kVA	0.4	25	16
	>250 kVA	0.32	20	13
<b>6 POLE</b> 1000 rpm 50Hz 1200 rpm 60Hz	>250 but =1250 kVA	0.32	20	13
	>1250	0.29	18	11

The 'Broad band' is taken as 2 Hz – 300 Hz

Table 6

If the vibration levels of the generating set are not within the parameters quoted above :-

1. Consult the genset builder. The genset builder should address the genset design to reduce the vibration levels as much as possible.
2. Discuss, with Newage, the impact of not meeting the above levels on both bearing and generator life expectancy.

Where requested, or deemed necessary, Newage will work with the genset builder in an attempt to find a satisfactory solution.

## BEARING 'SERVICE LIFE' EXPECTANCY

Bearing manufacturers recognise that the "service life" of their bearings is dependent upon many factors that are not in their control, they cannot therefore quote a "service life".

Although "service life" cannot be guaranteed, it can be maximised by attention to the generating set design. An understanding of the genset application will also help the user to maximise the service life expectancy of the bearings. Particular attention should be paid to the alignment, reduction of vibration levels, environmental protection, maintenance and monitoring procedures.

Newage does not quote life expectancy figures for bearings, but suggests practicable replacement intervals based on the L10 life of the bearing, the grease and the recommendations of the bearing and grease manufacturers.

For general-purpose applications, providing the vibration levels do not exceed the levels stated in ISO 8528-9\* and BS5000-3\* and the ambient temperature does not exceed 50°C the following approximations can be applied when planning bearing replacements.  
\*(see section on vibration)

Sealed for Life Bearings. - Approximately 30,000 hours.

Re-greaseable bearings. - Approximately 40,000 hours.

(Provided the correct maintenance is carried out, and only Kluber Asonic GHY 72 grease is used in all bearings.)

It is important to note that bearings in service, under good operating conditions, can continue to run beyond the recommended replacement period. It should also be remembered that the risk of bearing failure increases with time.

If in doubt about any aspect of the 'bearing life' on generators supplied by Newage International, contact your nearest Newage subsidiary or contact the Stamford factory direct.

See the back cover for addresses.

### 7.3 AIR FILTERS

Air filters for the removal of airbourne particulate matter (dust) are offered as an addition to the standard build option. Filters on Frame 6 and 7 need to be ordered with the generator but Frame 4 and 5 can have air filters fitted after the generator is built.

Air filters need to be changed with oil before the gen set is put to work (see 7.3.1).

The frequency of filter maintenance will depend upon the severity of the site conditions. Regular inspection of the elements will be required to establish when cleaning is necessary.

 <p><b>Danger !</b></p>	<p><b>Removal of filter elements enables access to LIVE parts. Only remove elements with the generator out of service.</b></p>
--	--

#### 7.3.1 CLEANING PROCEDURE

Remove the filter elements from the filter frames. Immerse or flush the element with a suitable degreasing agent until the element is clean.

As an alternative procedure a high pressure water hose with a flat nozzle can be used. Sweep the water spray back and forth across the element from the clean side (fine mesh side of element) holding the nozzle firmly against the element surface. Cold water may be adequate depending upon type of contamination although hot water is preferable.

The element can be inspected for cleanliness by looking through the filter towards the light.

When thoroughly clean, no cloudy areas will be seen. Dry elements thoroughly before attempting to carry out the recharging procedure.

#### 7.3.2 RECHARGING (CHARGING)

Charging is best done by totally immersing the dry element into a dip tank containing "Filterkote Type K" or commercial lubricating oil SAE 20/50. Oils of higher or lower viscosity are not recommended.

Allow elements to completely drain before refitting the elements into the frames and putting into service.

### 7.4 FAULT FINDING

**Important! Before commencing any fault finding procedures examine all wiring for broken or loose connections.**

Four types of excitation control system, involving four types of AVR, can be fitted to the range of generators covered by this manual. The systems can be identified by a combination of AVR type, where applicable, and the last digit of the generator frame size designation. Refer to the generator nameplate then proceed to the appropriate subsection as indicated below :-

DIGIT	EXCITATION CONTROL	SUBSECTION
4	SX440 AVR	7.4.1
4	SX421 AVR	7.4.2

3	MX341 AVR	7.4.3
3	MX321 AVR	7.4.4

#### 7.4.1 SX440 AVR - FAULT FINDING

No voltage build-up when starting set	<ol style="list-style-type: none"> <li>1. Check link K1-K2.</li> <li>2. Check speed</li> <li>3. Check residual voltage. Refer to subsection 7.4.5.</li> <li>4. Follow separate excitation tes procedure to check generator and AVR. Refer to subsection 7.5.</li> </ol>
Unstable voltage either on no-load or with load	<ol style="list-style-type: none"> <li>1. Check speed stability.</li> <li>2. Check stability setting. Refer to subsection 4.6.</li> </ol>
High voltage either on no-load or with load	<ol style="list-style-type: none"> <li>1. Check speed.</li> <li>2. Check that generator load is no capacitive (leading power factor).</li> </ol>
Low voltage no-load	<ol style="list-style-type: none"> <li>1. Check speed.</li> <li>2. Check link 1-2 or external hand trimmer leads for continuity.</li> </ol>
Low voltage on-load	<ol style="list-style-type: none"> <li>1. Check speed.</li> <li>2. Check UFRO setting. Refer to subsection 6.4.1.</li> <li>3. Follow separate excitation procedure to check generator and AVR. Refer to subsection 7.5.</li> </ol>

**Table 7**

#### 7.4.2 SX421 AVR - FAULT FINDING

No voltage build-up when starting set	<ol style="list-style-type: none"> <li>1. Check circuit breaker ON. Refer to subsection 6.4.1.</li> <li>2. Check speed</li> <li>3. Check residual voltage. Refer to subsection 7.4.5.</li> <li>4. Follow separate excitation tes procedure to check generator and AVR. Refer to subsection 7.5.</li> </ol>
Unstable voltage either on no-load or with load	<ol style="list-style-type: none"> <li>1. Check speed stability.</li> <li>2. Check stability setting. Refer to subsection 4.6.</li> </ol>
High voltage either on no-load or with load	<ol style="list-style-type: none"> <li>1. Check speed.</li> <li>2. Check link 1-2 or external hand trimmers leads for continuity. Check continuity of leads 7-8 and P3-P2 for continuity.</li> <li>3. Check that generator load is no capacitive (leading power factor).</li> </ol>
Low voltage no-load	<ol style="list-style-type: none"> <li>1. Check speed.</li> <li>2. Check link 1-2 or external hand trimmer leads for continuity.</li> </ol>
Low voltage on-load	<ol style="list-style-type: none"> <li>1. Check speed.</li> <li>2. Check UFRO setting. Refer to subsection 4.7.1.1.</li> <li>3. Follow separate excitation procedure to check generator and AVR. Refer to subsection 7.5.</li> </ol>
Excessive voltage/speed dip on load switching	<ol style="list-style-type: none"> <li>1. Check governor response.</li> <li>2. Refer to generating set manual Check 'DIP' setting. Refer to subsection 4.7.1.4.</li> </ol>

**Table 8**

### 7.4.3 MX341 AVR - FAULT FINDING

No voltage build-up when starting set	<ol style="list-style-type: none"> <li>1. Check link K1-K2 on auxiliary terminals</li> <li>2. Follow Separate Excitation Test Procedure to check machine and AVR. Refer to subsection 7.5.</li> </ol>
Loss of voltage when set running	<ol style="list-style-type: none"> <li>1. First stop and restart set. If no voltage or voltage collapses after short time, follow Separate Excitation Test Procedure. Refer to subsection 7.5.</li> </ol>
Generator Voltage high followed by collapse	<ol style="list-style-type: none"> <li>1. Check sensing leads to AVR.</li> <li>2. Refer to Separate Excitation Test Procedure. Refer to subsection 7.5.</li> </ol>
Voltage unstable, either on no-load or with load	<ol style="list-style-type: none"> <li>1. Check speed stability.</li> <li>2. Check "STAB" setting. Refer to Load Testing section for procedure. Refer to subsection 4.6.</li> </ol>
Low voltage no-load	<ol style="list-style-type: none"> <li>1. Check speed.</li> <li>2. Check link 1-2 or external hand trimmer leads for continuity.</li> </ol>
Low voltage on-load	<ol style="list-style-type: none"> <li>1. Check speed.</li> <li>2. If correct check "UFRO" setting. Refer to subsection 4.7.1.1.</li> </ol>
Excessive voltage/speed dip on load switching	<ol style="list-style-type: none"> <li>1. Check governor response. Refer to generating set manual. Check "DIP" setting. Refer to subsection 4.7.1.4.</li> </ol>
Sluggish recovery on load switching	<ol style="list-style-type: none"> <li>1. Check governor response. Refer to generating set manual.</li> </ol>

Table 9

### 7.4.4 MX321 AVR - FAULT FINDING

No voltage build-up when starting set	<ol style="list-style-type: none"> <li>1. Check link K1-K2 on auxiliary terminals. Follow Separate Excitation Test Procedure to check machine and AVR. Refer to subsection 7.5.</li> </ol>
Voltage very slow to build up	<ol style="list-style-type: none"> <li>1. Check setting of ramp potentiometer. Refer to 4.7.1.5.</li> </ol>
Loss of voltage when set running	<ol style="list-style-type: none"> <li>1. First stop and restart set. If no voltage or voltage collapses after short time, follow Separate Excitation Test Procedure. Refer to subsection 7.5.</li> </ol>
Generator Voltage high followed by collapse	<ol style="list-style-type: none"> <li>1. Check sensing leads to AVR.</li> <li>2. Refer to Separate Excitation Test Procedure. Refer to subsection 7.5.</li> </ol>
Voltage unstable, either on no-load or with load	<ol style="list-style-type: none"> <li>3. Check speed stability.</li> <li>4. Check "STAB" setting. Refer to Load Testing section for procedure. Refer to subsection 4.6.</li> </ol>
Low voltage On-load	<ol style="list-style-type: none"> <li>3. Check speed.</li> <li>4. If correct check "UFRO" setting. Refer to subsection 4.7.1.1.</li> </ol>
Excessive voltage/speed Dip on load Switching	<ol style="list-style-type: none"> <li>2. Check governor response. Refer to generating set manual. Check "DIP" setting. Refer to subsection 4.7.1.4.</li> </ol>
Sluggish recovery on load switching	<ol style="list-style-type: none"> <li>3. Check governor response. Refer to generating set manual.</li> </ol>

Table 10

### 7.4.5 RESIDUAL VOLTAGE CHECK

This procedure is applicable to generators with either SX460 or SX440 or SX421 AVR.

With the generator set stationary remove AVR access cover and disconnect leads X and XX from the AVR.

Start the set and measure voltage across AVR terminals P2-P3 on SX440 or SX421 AVR.

Stop the set, and replace leads X and XX on the AVR terminals. If the measured voltage was above 5V the generator should operate normally.

If the measured voltage was under 5V follow the procedure below.

### 7.4.6 'REFLASHING' TO RESTORE RESIDUAL

Using a 12 volt dc battery as a supply clip leads from battery negative to AVR terminal XX, and from battery positive through a diode to AVR terminal X. See Fig. 7.

**Important ! A diode must be used as shown below to ensure the AVR is not damaged.**

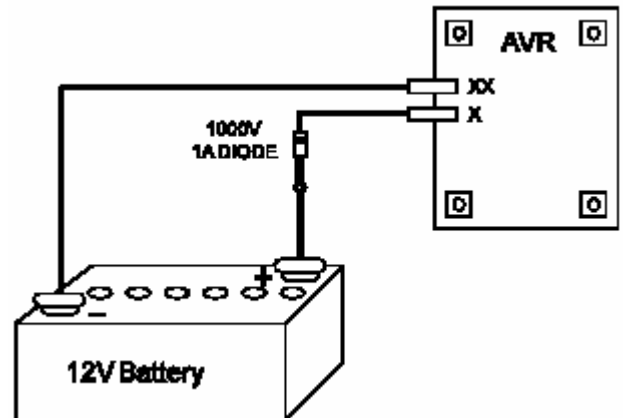

Fig. 7

**Important ! If the generating set battery is used for field flashing, the generator main stator neutral must be disconnected from earth.**

Restart the set and note output voltage from main stator, which should be approximately nominal voltage, or voltage at AVR terminals P2-P3 on SX440 or SX421 which should be between 170 and 250 volts.

Stop the set and unclip battery supply from terminals X and XX. Restart the set. The generator should now operate normally. If no voltage build-up is obtained it can be assumed a fault exists in either the generator or the AVR circuits. Follow the SEPARATE EXCITATION TEST PROCEDURE to check generator windings, rotating diodes and AVR. Refer to subsection 7.5.

## 7.5 SEPARATE EXCITATION TEST PROCEDURE

The generator windings, diode assembly and AVR can be checked using the appropriate following section.

7.5.1 GENERATOR WINDINGS, ROTATING DIODES and PERMANENT MAGNET GENERATOR (PMG)  
7.5.2 EXCITATION CONTROL TEST.

### 7.5.1 GENERATOR WINDINGS, ROTATING DIODES and PERMANENT MAGNET GENERATOR (PMG)

**Important ! The resistances quoted apply to a standard winding. For generators having windings or voltages other than those specified refer to factory for details. Ensure all disconnected leads are isolated and free from earth.**

**Important ! Incorrect speed setting will give proportional error in voltage output.**

#### CHECKING PMG

Start the set and run at rated speed.

Measure the voltages at the AVR terminals P2, P3 and P4. These should be balanced and within the following ranges :-

50Hz generators - 170-180 volts  
60Hz generators - 200-216 volts

Should the voltages be unbalanced stop the set, remove the PMG sheet metal cover from the non drive endbracket and disconnect the multipin plug in the PMG output leads. Check leads P2, P3, P4 for continuity. Check the PMG stator resistances between output leads. These should be balanced and within +/-10% of 2.3 ohms. If resistances are unbalanced and/or incorrect the PMG stator must be replaced. If the voltages are balanced but low and the PMG stator winding resistances are correct - the PMG rotor must be replaced.

#### CHECKING GENERATOR WINDINGS AND ROTATING DIODES

This procedure is carried out with leads X and XX disconnected at the AVR or transformer control rectifier bridge and using a 12 volt d.c. supply to leads X and XX.

Start the set and run at rated speed.

Measure the voltages at the main output terminals U, V and W. If voltages are balanced and within +/-10% of the generator nominal voltage, refer to 7.5.1.1.

Check voltages at AVR terminals 6, 7 and 8. These should be balanced and between 170-250 volts.

If voltages at main terminals are balanced but voltage at 6, 7 and 8 are unbalanced, check continuity of leads 6, 7 and 8. Where an isolating transformer is fitted (MX321 AVR) check transformer windings. If faulty the transformer unit must be replaced.

If voltages are unbalanced, refer to 7.5.1.2.

### 7.5.1.1 BALANCED MAIN TERMINAL VOLTAGES

If all voltages are balanced within 1% at the main terminals, it can be assumed that all exciter windings, main windings and main rotating diodes are in good order, and the fault is in the AVR or transformer control. Refer to subsection 7.5.2 for test procedure.

If voltages are balanced but low, there is a fault in the main excitation windings or rotating diode assembly. Proceed as follows to identify :-

#### Rectifier Diodes

The diodes on the main rectifier assembly can be checked with a multimeter. The flexible leads connected to each diode should be disconnected at the terminal end, and the forward and reverse resistance checked. A healthy diode will indicate a very high resistance (infinity) in the reverse direction, and a low resistance in the forward direction. A faulty diode will give a full deflection reading in both directions with the test meter on the 10,000 ohms scale, or an infinity reading in both directions. On an electronic digital meter a healthy diode will give a low reading in one direction, and a high reading in the other.

#### Replacement of Faulty Diodes

The rectifier assembly is split into two plates, the positive and negative, and the main rotor is connected across these plates. Each plate carries 3 diodes, the negative plate carrying negative biased diodes and the positive plate carrying positive biased diodes. Care must be taken to ensure that the correct polarity diodes are fitted to each respective plate. When fitting the diodes to the plates they must be tight enough to ensure a good mechanical and electrical contact, but should not be overtightened. The recommended torque tightening is 4.06 - 4.74Nm (36-42lb in).

#### Surge Suppressor

The surge suppressor is a metal-oxide varistor connected across the two rectifier plates to prevent high transient reverse voltages in the field winding from damaging the diodes. This device is not polarised and will show a virtually infinite reading in both directions with an ordinary resistance meter. If defective this will be visible by inspection, since it will normally fail to short circuit and show signs of disintegration. Replace if faulty.

#### Main Excitation Windings

If after establishing and correcting any fault on the rectifier assembly the output is still low when separately excited, then the main rotor, exciter stator and exciter rotor winding resistances should be checked (see Resistance Charts), as the fault must be in one of these windings. The exciter stator resistance is measured across leads X and XX. The exciter rotor is connected to six studs which also carry the diode lead terminals. The main rotor winding is connected across the two rectifier plates. The respective leads must be disconnected before taking the readings.

Resistance values should be within +/-10% of the values given in the tables below :-

4 POLE GENERATORS			
FRAME SIZE	MAIN ROTOR	EXCITER STATOR	EXCITER ROTOR
4 - 4C	0.91	18	0.136
4 - 4D	1.04	18	0.136
4 - 4E	1.17	18	0.136
4 - 4F	1.35	18	0.136
5 - 4C	1.55	17	0.184
5 - 4D	1.77	17	0.184
5 - 4E	1.96	17	0.184
5 - 4F	2.16	17	0.184
6 - 4G	1.75	17	0.158
6 - 4H	1.88	17	0.158
6 - 4J	2.09	17	0.158
6 - 4K	2.36	17	0.158
7 - 4E	1.27	17	0.096
7 - 4F	1.41	17	0.096
7 - 4G	1.65	17	0.096
7 - 4H	1.77	17	0.096

Table 11

6 POLE GENERATORS			
FRAME SIZE	MAIN ROTOR	EXCITER STATOR	EXCITER ROTOR
6 - 6G	1.12	17	0.2
6 - 6H	1.33	17	0.2
6 - 6J	1.5	17	0.2
6 - 6K	1.75	17	0.2
7 - 6E	2.33	17	0.2
7 - 6F	2.83	17	0.2
7 - 6G	3.25	20	0.28

Table 12

### 7.5.1.2 UNBALANCED MAIN TERMINAL VOLTAGES

If voltages are unbalanced, this indicates a fault on the main stator winding or main cables to the circuit breaker.

NOTE: Faults on the stator winding or cables may also cause noticeable load increase on the engine when excitation is applied.

Disconnect the main cables and separate the winding leads U1-U2, (U5-U6), V1-V2, (V5-V6), W1-W2, (W5-W6) to isolate each winding section.

Note:- leads suffixed 5 and 6 apply to 12 wire windings only.

Measure each section resistance - values should be balanced and within +/-10% of the value given below:-

MAIN STATOR SECTION RESISTANCES				
4 POLE GENERATORS				
SECTION RESISTANCES				
FRAME SIZE	WINDING 311 1-2 OR 5-6	WINDING 12 1-2	WINDING 17 1-2 OR 5-6	WINDING 07 1-2
4 - 4C	0.0085	N/A	0.0115	N/A
4 - 4D	0.006	N/A	0.01	N/A
4 - 4E	0.0045	N/A	0.0075	N/A
4 - 4F	0.0037	N/A	0.0055	N/A
5 - 4C	0.0032	N/A	0.0053	N/A
5 - 4D	0.0024	N/A	0.0004	N/A
5 - 4E	0.0022	N/A	0.0034	N/A
5 - 4F	0.0019	N/A	0.0025	N/A
6 - 4G	0.0017	0.0034	N/A	0.0055
6 - 4H	0.0013	0.0025	N/A	0.0036
6 - 4J	0.0011	0.0022	N/A	0.003
6 - 4K	0.0085	0.0017	N/A	0.0026
7 - 4E	N/A	0.0016	N/A	0.0026
7 - 4F	N/A	0.0013	N/A	0.002
7 - 4G	N/A	0.0009	N/A	0.0015
7 - 4H	N/A	0.0008	N/A	0.0011

Table 13

4 POLE GENERATORS				
SECTION RESISTANCES				
FRAME SIZE	WINDING 311 1-2 OR 5-6	WINDING 12 1-2	WINDING 17	WINDING 07 1-2
6 - 6G	0.0045	0.009	N/A	0.015
6 - 6H	0.0032	0.0063	N/A	0.01
6 - 6J	N/A	0.0049	N/A	0.007
6 - 6K	0.002	0.0039	N/A	0.006
7 - 6E	N/A	0.0027	N/A	0.0042
7 - 6F	N/A	0.0018	N/A	0.0032
7 - 6G	N/A	0.0014	N/A	0.002

Table 14

Measure insulation resistance between sections and each section to earth.

Unbalanced or incorrect winding resistances and/or low insulation resistances to earth indicate rewinding of the stator will be necessary. Refer to removal and replacement of component assemblies subsection 7.5.3.

## 7.5.2 EXCITATION CONTROL TEST

### 7.5.2.1 AVR FUNCTION TEST

All types of AVR's can be tested with this procedure :

1. Remove exciter field leads X & XX (F1 & F2) from the AVR terminals X & XX (F1 & F2).
2. Connect a 60W 240V household lamp to AVR terminals X & XX (F1 & F2).
3. Set the AVR VOLTS control potentiometer fully clockwise.
4. Connect a 12V, 1.0A DC supply to the exciter field leads X & XX (F1 & F2) with X (F1) to the positive.
5. Start the generating set and run at rated speed.
6. Check that the generator output voltage is within +/- 10% of rated voltage.

Voltages at AVR terminals 7-8 on SX460 AVR or P2-P3 on SX440 or SX421 AVR should be between 170 and 250 volts. If the generator output voltage is correct but the voltage on 7-8 (or P2- P3) is low, check auxiliary leads and connections to main terminals.

Voltages at P2, P3, P4 terminals on MX341 and MX321 should be as given in 7.5.1.

The lamp connected across X-XX should glow. In the case of the SX460, SX440 and SX421 AVRs the lamp should glow continuously. In the case of the MX341 and MX321 AVRs the lamp should glow for approximately 8 secs. and then turn off. Failure to turn off indicates faulty protection circuit and the AVR should be replaced. Turning the "VOLTS" control potentiometer fully anti-clockwise should turn off the lamp with all AVR types.

Should the lamp fail to light the AVR is faulty and should be replaced.

**Important ! After this test turn VOLTS control potentiometer fully anti-clockwise.**

## 7.5.3 REMOVAL AND REPLACEMENT OF COMPONENT ASSEMBLIES

METRIC THREADS ARE USED THROUGHOUT

**When lifting single bearing generators, care is needed to ensure the generator frame is kept in the horizontal plane. The rotor is free to move in the frame and can slide out if not correctly lifted. Incorrect lifting can cause serious injury to personnel.**

### 7.5.3.1 ANTI-CONDENSATION HEATERS



**Danger !**

The external mains electricity supply used to power the anti-condensation heater must be switched off and safely isolated before attempting any work adjacent to the heater, or removal of the non drive end endbracket on which the anti-con heater is mounted. Ensure that the engine is inhibited prior to work in generator.

### 7.5.3.2 REMOVAL OF PERMANENT MAGNET GENERATOR (PMG)

1. Remove access cover.
2. Disconnect P2, P3, P4 at the multiway connector inside the access cover.
3. Remove the 4 screws and clamps retaining the stator housing (Frames 4, 5 and 6) or the stator pack (Frame 7).
4. Tap the stator pack or housing out of its spigot.

NOTE:

As the highly magnetic rotor will attract the stator core, care must be taken to avoid a contact which may damage the winding.

5. Remove the exciter rotor securing bolt and stow safely and firmly pull the complete rotor assembly from its location.

N.B. Keep the rotor clean and avoid contact with metal dust or particles - preferably place in plastic bag.

**Important ! The rotor assembly must not be dismantled.**

Re-assembly is a reversal of the above procedure having due regard for the notes below:-

1. Ensure rotor magnet assembly is free of metal pieces or particles.
2. Care is needed to avoid winding damage when re-assembling the stator pack, due to strong magnetic attraction.

### 7.5.3.3 REMOVAL OF BEARINGS

**Important ! Position the main rotor so that a full pole face of the main rotor core is at the bottom Remove PMG of the stator bore if fitted.**

The generators in this manual will be fitted with one of three different bearing arrangements. There may be two different arrangements on a two-bearing generator. (See table 14 & 15)

BEARING OPTION FOR DRIVE-END BEARINGS				
	HC4	HC5	HC6	HC7
Regreasable bearings	N/A	OPT	OPT	STD
Sealed for life with a cartridge	STD	STD	STD	N/A
Sealed for life without cartridge	N/A	N/A	N/A	N/A

**Table 15**

<b>BEARING OPTION FOR NON DRIVE-END BEARINGS</b>				
	<b>HC4</b>	<b>HC5</b>	<b>HC6</b>	<b>HC7</b>
Regreasable bearings	N/A	OPT	OPT	STD
Sealed for life with a cartridge	N/A	N/A	STD	N/A
Sealed for life without cartridge	STD	STD	N/A	N/A

**Table 16**

Removal of the bearings may be effected either after the rotor assembly has been removed or more simply by removal of endbracket(s).

**Be sure to note the location of all components during removal to assist during the assembly process.**

## **BEARING REPLACEMENT**

### **Environment**

Every effort must be made to establish a clean area around the generator when removing and replacing bearings. Contamination is a major cause of bearing failures.

### **Equipment**

Suitable cleaning solvent  
Bearing puller, two or three leg  
Thin protective gloves  
Lint free cleaning cloth  
Induction heater.

### **Preparation**

Remove PMG if fitted  
Remove the lubrication pipework if fitted  
Position the rotor so that the full pole face of the main rotor is at the bottom of the stator bore.  
Remove the end bracket, see 7.5.3.4 for procedure.

#### **NOTES:**

- It is not necessary to remove the rotor.
- Ensure that the bearing contact surfaces shows no sign of wear or corrosion prior to fitting the bearing.
- Never refit used bearings, wave washers or 'O'rings.
- Never refit used bearings, grease flingers, wave washer or 'O' rings.
- Only the outer race should be used to transmit load during assembly (NEVER use the inner race).

## **REMOVAL OF REGREASABLE BEARINGS**

The bearings are a press fit on the shaft and can be removed with standard tooling, i.e. 2 or 3 legged manual or hydraulic bearing pullers.

To remove bearings proceed as follows :

1. Remove 4 screws holding bearing cap.
2. Remove cap.
3. Non drive end - remove wave washer and circlip (single bearing only).
4. Remove bearing cartridge housing complete with bearing (and grease flinger if fitted).
5. Remove bearing from cartridge.
6. Discard the old bearing 'O' rings and wave washer where fitted.

The bearing cap(s) and cartridge(s) must be thoroughly flushed out with clean solvent and checked for wear or damage, before re-assembly. Damaged components should be replaced before refitting the bearing.

## **ASSEMBLY OF REGREASABLE BEARINGS**

NOTE: Gloves must be worn at all times when handling the bearings, grease and solvent.

1. Wipe clean the assembly surface, using cleaning solvent on lint free cloth.
2. Wipe clean: Bearing Cartridge, Wave Washer, Bearing Cap, grease flinger, all re-lubrication pipes and fittings (internal and external). Visually inspect all components after cleaning, for contamination.
3. Place all components on the clean assembly surface. Do not use an air line to blow off excess fluid.
4. Thoroughly clean the external surface of the grease gun nozzle using lint free cloth.

### **Bearing preparation**

1. Remove the bearing from its packaging.
2. Wipe off the preservative oil from the surface of the inner and outer rings - using lint free cloth only.
3. Place the bearing on the clean assembly surface, with the bearing designation marking facing down.

### **Bearing Assembly ( Lubrication, see TABLE 17)**

#### **Cartridge:**

1. Apply the specified cartridge grease fill quantity to the back face of the bearing housing.
2. Apply a small amount of grease to the grooved sealing surface in the cartridge.
3. Apply anti-fretting lubricant (MP14002 - Klüber Altemp Q NB 50) to the bearing housing circumference. Apply paste in a thin coherent layer by use of a lint free cloth (DO NOT rub in) (use clean protective gloves).
4. Non-drive end - fit new 'O' Rings into the 'O' Ring grooves in the bearing housing circumference.

#### **Bearing:**

1. Apply half the specified bearing grease fill quantity (see table 16) to the upper face of the bearing (opposite side to the bearing designation markings).
2. Thumb the applied grease into the bearing, ensuring good penetration into the raceways/balls (use clean protective gloves).

### **Assemble Bearing into Cartridge**

1. Heat the bearing cartridge to 25° C above ambient with an induction heater ( Do not exceed 100°C).

2. With greased face of the bearing facing the cartridge bore, assemble the bearing into the bearing housing. Ensure the bearing outer race contacts the location shoulder.

## Assemble Bearing onto Shaft

### Bearing Cartridge

1. Heat the Bearing and Cartridge assembly to 80°C above ambient with an induction heater. ( use induction heater, no other heat source is suitable)
2. Slide the Bearing and Cartridge assembly over the shaft, pushing it firmly against the bearing seating shoulder.
3. Rotate the assembly (including inner race) 45° in either direction, to provide correct alignment. The bearing must be held firmly in place until it is cool enough to positively self locate.

NOTE : Ensure cartridge is at ambient temp. before assembling bracket.

### Cap/Flinger:

Apply the specified cap grease fill quantity to the inside face of the cap (see table 16).

1. Fill the grease exhaust slot with grease.
2. Apply a small amount of grease to the grooved sealing surface in the cap.
3. Fit circlip.  
(single bearing only).
4. Heat flinger to 120°C and place on shaft up to the bearing inner race. Hold firmly until positively located.
5. Place wave washer in cap, fit cap to bearing cartridge.

### Re-lubrication pipe:

1. Fill pipe and grease nipple with grease.
2. Fit pipe work to machine.

INITIAL LUBRICATION DETAILS, REGREASABLE BEARINGS							
FRAME	BEARING POSITION	GREASE QUANTITY					
		BEARINGS		CARTRIDGE		CAP	
		CM <sup>3</sup>	GRAMS	CM <sup>3</sup>	GRAMS	CM <sup>3</sup>	GRAMS
5	Non-Drive End	65	58	33	29	33	29
5	Drive End	92	82	46	41	46	41
6	Non-Drive End	121	111	63	56	63	56
6	Drive End	156	139	78	69	78	69
7	Non-Drive End	174	154	87	77	87	77
7	Drive End	208	185	104	92	104	92

Lubricant : Kluber Asonic GHY 72

Table 17

## REMOVAL OF GREASED FOR LIFE BEARINGS WITH BEARING CARTRIDGE

The bearings are a press fit on the shaft and can be removed with standard tooling, i.e. 2 or 3 legged manual or hydraulic bearing pullers.

To remove bearings proceed as follows :

1. Remove 4 screws holding bearing cap.
2. Remove cap.
3. Non drive end - remove wave washer and circlip (single bearing only).
4. Remove bearing cartridge housing complete with bearing.
5. Remove bearing from cartridge.
6. Discard the old bearing, 'o' rings and wave washer where fitted.

The bearing cap(s) and cartridge(s) must be thoroughly flushed out with clean solvent and checked for wear or damage, before re-assembly. Damaged components should be replaced before refitting the bearing.

## ASSEMBLY OF SEALED FOR LIFE BEARINGS WITH CARTRIDGE

### Pre-assembly cleaning.

NOTE: Gloves must be worn at all times when handling the bearings, grease and solvent.

1. Wipe clean the assembly surface, using cleaning solvent on lint free cloth.
2. Wipe clean: Bearing Cartridge and Bearing Cap (internal and external). Visually inspect all components after cleaning, for contamination.
3. Place all components on a clean assembly surface. Do not use an air line to blow off excess fluid.
4. Thoroughly clean the external surface of the grease gun nozzle using lint free cloth.

### Bearing preparation:

1. Remove the bearing from its packaging.
2. Wipe off the preservative oil from the surface of the inner and outer rings - using lint free cloth only.
3. Place the bearing on the clean assembly surface, with the bearing designation marking facing down.

## Bearing Assembly

### Cartridge :

1. Apply anti-fretting lubricant (**MP14002 - Klüber Altemp Q NB 50**) to the bearing housing circumference. Apply paste in a thin coherent layer by use of a lint free cloth (**DO NOT rub in**) (use clean protective gloves).
2. Fit 'O' Rings into the 'O' Ring grooves in the bearing housing circumference.

### Assemble Bearing into Cartridge

1. Heat the bearing cartridge to 25° C above the ambient temperature (with an induction heater, do not exceed 100°C) and assemble the new bearing into the cartridge. Ensure that the bearing designation is visible after assembly.
2. With greased face of the bearing facing the cartridge bore, assemble the bearing into the bearing housing. Ensure the bearing outer race contacts the location shoulder.

NOTE: Only the outer race should be used to transmit load during assembly (NEVER use the inner race).

### Assemble Bearing and Cartridge onto the Shaft

1. Heat the Bearing and Cartridge assembly to 80°C above ambient. ( use induction heater, no other heat source is suitable)
2. Slide the Bearing and Cartridge assembly over the shaft, pushing it firmly against the bearing seating shoulder.
3. Rotate the assembly (including inner race) 45° in either direction, to provide correct alignment. The bearing must be held firmly in place until it is cool enough to positively self locate.
4. Non drive end only - fit circlip (single bearing only) and wave washer.
5. Fit the bearing cap.
6. Rotate the bearing assembly on the shaft to check for free movement.

Note : Ensure cartridge is at ambient temp. before assembling bracket.

7. Refit the end bracket and PMG where fitted.

### SEALED FOR LIFE BEARINGS (WITHOUT CARTRIDGE)

NOTE : Prior to commencement of removal of end bracket ensure rotor is positioned with full pole face at the bottom of the stator bore.

## Preparation

1. Remove terminal box lid.
2. Cut cable ties and disconnect exciter leads.
3. Remove bolts from NDE terminal panel and place panel over terminal board with AVR still connected.
4. Remove Permanent Magnet Generator (if fitted) see 7.5.3.2.
5. Remove the rotor retaining circlip (Non drive end – single bearing only) and slack off remaining NDE bracket bolts.
6. Fit 2 off M10x60mm bolts into jacking locations on centre line and replace 2 bolts into end bracket for support as end bracket is removed (be aware of exciter lead and PMG lead, if fitted).
7. If alternator not connected to engine be aware of rotor pulling through stator, to avoid this, place wooden spacer between fan and frame each side at drive end.
8. Use available lifting equipment to remove the bracket.
9. Remove bearing circlip (Non drive end - single bearing only).

## BEARING REMOVAL

1. Fit pulley drawers and draw off bearing, ensuring to protect the threaded hole in the end of the main shaft.
2. Heat the Bearing to 80°C above ambient with an induction heater and fit to shaft. ( use induction heater, no other heat source is suitable do not exceed 100°C); (ensure shaft and bearing are clean prior to assembly)
3. Replace the bearing circlip (single bearing only).

## Replace the Endbracket

1. Remove jacking bolts from end bracket and lift end bracket into position and fit bracket onto bearing (heat bracket if required). Ensure exciter and PMG leads are pulled through end positioned.
2. Lift rotor to align exciter (use piece of wood as lever under shaft through NDE aperture) fit bolts and secure evenly around end bracket to ensure it is correctly aligned.
3. Replace rotor retaining circlip and permanent magnet assembly if fitted, and replace cover.
4. Connect exciter and re-tie all cables into position and reassemble terminal box.

NOTE: Prior to re-fitting end bracket check exciter electrically and physically to ensure no damaged caused when dismantling.

### 7.5.3.4 MAIN ROTOR ASSEMBLY

#### SINGLE BEARING MACHINE

NOTE: On single bearing machines, before removal from, or re-assembly to the prime mover, position the rotor, if possible, such that a full pole face is at bottom dead centre.

1. Remove all access covers and terminal box lid.
2. Disconnect exciter leads X and XX and PMG leads P2-P3-P4 at the auxiliary terminals inside the terminal box.
3. Ensure that these leads are free to come away with the non drive end bracket when removed.
4. Remove the 8 bolts holding the drive end adaptor to the frame.
5. With a rope sling around drive end adaptor, tap adaptor out of its spigot location; guide over fan and remove.
6. If the generator is fitted with a cartridge. Remove the 4 bolts retaining the non drive end bearing cartridge in the non drive end endbracket (outer 4 bolts). (This includes all regreasable options).
7. Remove the 8 bolts securing the non drive end bracket to the frame.
8. Supporting the non drive end bracket with a hoist, insert two M10 bolts in the two holes provided for 'jacking' purposes (on the end bracket horizontal centre line). Screw in the bolts until the end bracket spigot is clear of the locating recess, lower the whole assembly until the main rotor is resting in the stator bore. Still supporting the non drive end bracket, tap the bracket off the non drive end bearing cartridge (taking care that the exciter stator does not foul exciter rotor windings) and remove.
9. To withdraw the rotor from the stator the rotor must be supported by a rope at the drive end and eased out of the stator core until half the main rotor is protruding out of the stator. At this point it is safe to release the weight from the rope sling.
10. Tightly bind a rope sling around the rotor core, and supporting the non drive end of the rotor, guide it clear of the stator.



**Warning !**

**The rope sling may not be at the centre of gravity of the rotor and guidance at the ends of the rotor is essential. THE FULL WEIGHT OF THE ROTOR GIVEN IN THE TABLE BELOW MUST BE SUPPORTED BY THE CRANE AND SLING. If the rotor core is allowed to drop more than a few millimetres at this point, it will make contact with the stator windings and may damage them.**

#### MINIMUM ROTOR ASSEMBLY WEIGHTS

FRAME	WEIGHT
4 - 4 pole	473 kgs
5 - 4 pole	685 kgs
6 - 4 pole	1093 kgs
6 - 6 pole	1050 kgs
7 - 4 pole	1592 kgs
7 - 6 pole	1790 kgs

Re-assembly is a reversal of the above procedure.

Before assembly of a single bearing rotor into stator housing check that the drive discs are not damaged or cracked or showing any other signs of fatigue. Also check that holes in the discs for drive fixing screws are not elongated.

Damaged components must be replaced.

When refitting discs ensure that the number and thickness of discs, and the tightening torque of hub bolts is in accordance with the table below.

Refer to engine manual for torque setting of disc to flywheel bolts.

FRAME	NO. OF DISCS	SINGLE DISC THICKNESS	TOTAL THICKNESS	TIGHTENING TORQUE
4	4	1.2	4.8	48kgm
				479Nm
5	4	1.2	4.8	48kgm
				479Nm
6	6	1.2	7.2	84kgm
				822Nm
7	6	1.2	7.2	84kgm
				822Nm

**Table 18**

#### TWO BEARING MACHINES

NOTE:

Position rotor, if possible, such that a full pole face is at bottom dead centre.

The procedure for removal of a two bearing rotor is similar to that outlined for single bearing machines with the exception of Steps 4 and 5 relating to the drive end adaptor.

For removal of this item proceed as follows :-

1. Remove the 8 bolts holding drive end adaptor to frame and 4 bolts retaining bearing cartridge in drive end bracket (outer 4 bolts), if fitted.
2. With rope sling around the shaft extension, supporting the rotor weight tap the drive end bracket spigot out of its locating recess and lower rotor assembly to rest in the stator bore.
3. Take the weight of the drive end bracket on the sling and tap the bracket off the drive end bearing cartridge, guide over the fan and remove.

Re-assembly is a reversal of the above procedure.

## 7.6 RETURNING TO SERVICE

After rectification of any faults found, remove all test connections and reconnect all control system leads. Restart the set and adjust VOLTS control potentiometer on AVR by slowly turning clockwise until rated voltage is obtained. Refit all terminal box covers/access covers and reconnect heater supply.

**Failure to refit all guards, access covers and terminal box covers can result in personal injury or death.**

## 7.7 MAINTENANCE

### Re-lubrication

1. Ensure grease gun nozzle and re-lubrication nipple are free from contaminants or abrasive material.
2. Apply the specified re-lubrication grease fill quantity (see table below) via the grease nipple.
3. Run the machine for 10 minutes to allow excess grease to exhaust.

Check inside the non-drive end PMG cover for expelled grease. Clean out as necessary.

RELUBRICATION DETAILS FOR REGREASABLE BEARINGS				
HC/HCK	BEARING POSITION	GREASE QUANTITY		RELUBRICATION PERIOD
		CM <sup>3</sup>	GRAMS	
5	Non-Drive End	33	29	4,500 Hrs
5	Drive End	46	41	4,500 Hrs
6	Non-Drive End	60	53	4,500 Hrs
6	Drive End	75	66	4,500 Hrs
7	Non-Drive End	85	75	4,500 Hrs
7	Drive End	100	89	4,500 Hrs

**Table 19**

# SECTION 8

## SPARES AND AFTER SALES SERVICE

### 8.1 RECOMMENDED SPARES

Service parts are conveniently packaged for easy identification. Genuine parts may be recognised by the Nupart name.

We recommend the following for Service and Maintenance. In critical applications a set of these service spares should be held with the generator.

1. **Diode Set (6 diodes with Surge Suppressors)**  
**HC4/5**                                 **RSK5001**  
**HC6/7**                                 **RSK6001**
  
2. **SX440 AVR**                                 **E000-24030**  
**SX421 AVR**                                 **E000-24210**  
**MX321 AVR**                                 **E000-23212**  
**MX341 AVR**                                 **E000-23412**
  
3. **Bearings**

<b>PART NUMBERS NON DRIVE-END BEARINGS</b>				
	<b>HC4</b>	<b>HC5</b>	<b>HC6</b>	<b>HC7</b>
Regreasable bearings	N/A	OPT 051-01068	OPT 051-01065	STD 051-01063
Sealed for life with a cartridge	N/A	N/A	STD 051-01070	N/A
Sealed for life without cartridge	STD 051-01072	STD 051-01072	N/A	N/A

**Table 20**

<b>PART NUMBERS DRIVE-END BEARINGS</b>				
	<b>HC4</b>	<b>HC5</b>	<b>HC6</b>	<b>HC7</b>
Regreasable bearings	N/A	OPT 051-01067	OPT 051-01064	STD 051-01062
Sealed for life with a cartridge	STD 051-01070	STD 051-01071	STD 051-01069	N/A
Sealed for life without cartridge	N/A	N/A	N/A	N/A

**Table 21**

When ordering parts the machine serial number or machine identity number and type should be quoted, together with the part description. For location of these numbers see paragraph 1.3.

Orders and enquiries for parts should be addressed to :

Newage International Ltd.,  
 Nupart Department,  
 P O Box 17, Barnack Road,  
 Stamford,  
 Lincolnshire  
 PE9 2NB  
 England.

Telephone: 44 (0) 1780 484000  
 Fax: 44 (0) 1780 766074

**Website: [www.newagestamford.com](http://www.newagestamford.com)**

or any of our subsidiary companies listed on the back cover.

### 8.2 AFTER SALES SERVICE

A full technical advice and on-site service facility is available from our Service Department at Stamford or through our subsidiary companies. A repair facility is also available at our Stamford Works.



## **A.C. GENERATOR WARRANTY**

### **WARRANTY PERIOD**

#### **A.C. Generators**

In respect of a.c. generators the Warranty Period is eighteen months from the date when the goods have been notified as ready for despatch by N.I. or twelve months from the date of first commissioning (whichever is the shorter period).

### **DEFECTS AFTER DELIVERY**

We will make good by repair or, at our option, by the supply of a replacement, any fault which under proper use appears in the goods within the period specified on Clause 12, and is found on examination by us to be solely due to defective material and workmanship; provided that the defective part is promptly returned, carriage paid, with all identification numbers and marks intact, or our works or, if appropriate to the Dealer who supplied the goods.

Any part repaired or replaced, under warranty, will be returned by N.I. free of charge (via sea freight if outside the UK).

We shall not be liable for any expenses which may be incurred in removing or replacing any part sent to us for inspection or in fitting any replacement supplied by us. We shall be under no liability for defects in any goods which have not been properly installed in accordance with N.I. recommended installation practices as detailed in the publications 'N.I. Installation, Service and Maintenance Manual' and 'N.I. Application Guidelines', or which have been improperly stored or which have been repaired, adjusted or altered by any person except ourselves or our authorised agents, or in any second-hand goods, proprietary articles or goods not of our own manufacture although supplied by us, such articles and goods being covered by the warranty (if any) given by the separate manufacturers.

Any claim under this clause must contain fully particulars of the alleged defect, the description of the goods, the date of purchase, and the name and address of the Vendor, the Serial Number (as shown on the manufacturers identification plate) or for Spares the order reference under which the goods were supplied.

Our judgement in all cases of claims shall be final and conclusive and the claimant shall accept our decision on all questions as to defects and the exchange of a part or parts.

Our liability shall be fully discharged by either repair or replacement as above, and in any event shall not exceed the current list price of the defective goods.

Our liability under this clause shall be in lieu of any warranty or condition implied by law as to the quality or fitness for any particular purpose of the goods, and save as expressly provided in this clause we shall not be under any liability, whether in contract, tort or otherwise, in respect of defects in goods delivered or for any injury, damages or loss resulting from such defects or from any work undone in connection therewith.

MACHINE SERIAL NUMBER

--

# NEWAGE INTERNATIONAL LIMITED

REGISTERED OFFICE AND ADDRESS:  
PO BOX 17  
BARNACK ROAD  
STAMFORD  
LINCOLNSHIRE  
PE9 2NB ENGLAND

Telephone: 44 (0) 1780 484000  
Fax: 44 (0) 1780 484100  
Web site: www.newagestamford.com

## SUBSIDIARY COMPANIES



1. AUSTRALIA : NEWAGE ENGINEERS PTY. LIMITED  
PO Box 6027, Baulkham Hills Business Centre,  
Baulkham Hills NSW 2153.  
Telephone: Sydney (61) 2 9680 2299  
Fax: (61) 2 9680 1545
2. CHINA: WUXI NEWAGE ALTERNATORS LIMITED  
Plot 49-A, Xiang Jiang Road  
Wuxi High - Technical Industrial Dev. Zone  
Wuxi, Jiangsu 214028  
PR of China  
Tel: (86) 51 027 63313  
Fax: (86) 51 052 17673
3. GERMANY: NEWAGE ENGINEERS G.m.b.H.  
Rotenbrückenweg 14, D-22113 Hamburg.  
Telephone: Hamburg (49) 40 714 8750  
Fax: (49) 40 714 87520
4. INDIA: C.G. NEWAGE ELECTRICAL LIMITED  
C33 Midc, Ahmednagar 414111, Maharashtra.  
Telephone: (91) 241 778224  
Fax: (91) 241 777494
5. ITALY: NEWAGE ITALIA S.r.l.  
Via Triboniano, 20156 Milan.  
Telephone: Milan (39) 02 380 00714  
Fax: (39) 02 380 03664
6. JAPAN: NEWAGE INTERNATIONAL JAPAN  
8 - 5 - 302 Kashima  
Hachioji-shi  
Tokyo, 192-03  
Telephone: (81) 426 77 2881  
Fax: (81) 426 77 2884
7. NORWAY: NEWAGE NORGE A/S  
Økern Naeringspark, Kabeigt. 5  
Postboks 28, Økern, 0508 Oslo  
Telephone: Oslo (47) 22 97 44 44  
Fax: (47) 22 97 44 45
8. SINGAPORE: NEWAGE ASIA PACIFIC PTE LIMITED  
10 Toh Guan Road #05-03  
TT International Tradepark  
Singapore 608838  
Telephone: Singapore (65) 794 3730  
Fax: (65) 898 9065  
Telex: RS 33404 NEWAGE
9. SPAIN: STAMFORD IBERICA S.A.  
Ctra. Fuenlabrada-Humanes, km.2  
Poligono Industrial "Los Linares"  
C/Pico de Almanzor, 2  
E-28970 HUMANES DE MADRID (Madrid)  
Telephone: Madrid (34) 91 604 8987/8928  
Fax: (34) 91 604 81 66
10. U.S.A.: NEWAGE LIMITED  
4700 Main St, N.E.  
Fridley  
Minnesota 55421  
Telephone: (1) 800 367 2764  
Fax: (1) 800 863 9243